

# Catalogue

## Series P3N 3C/O Relay

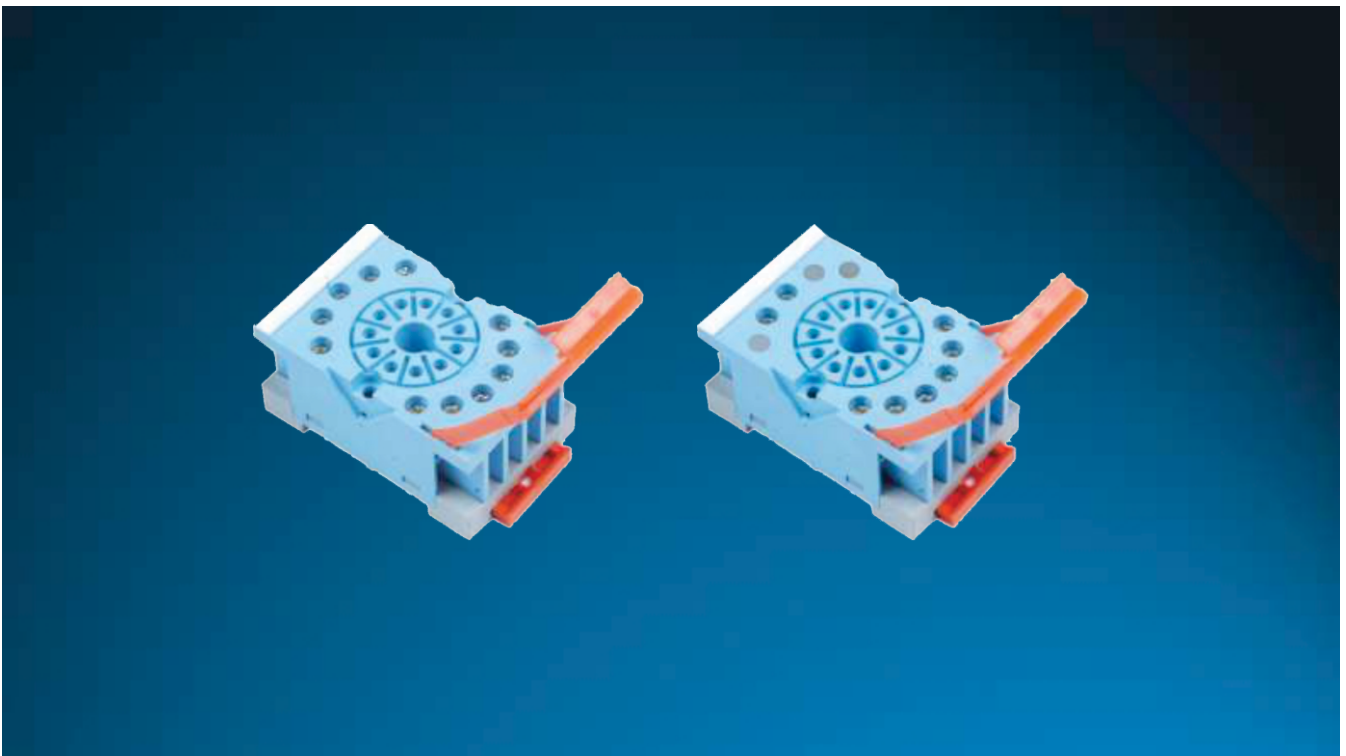

Benefits  
of the new



**PARAMOUNT**  
EXPECT MORE...

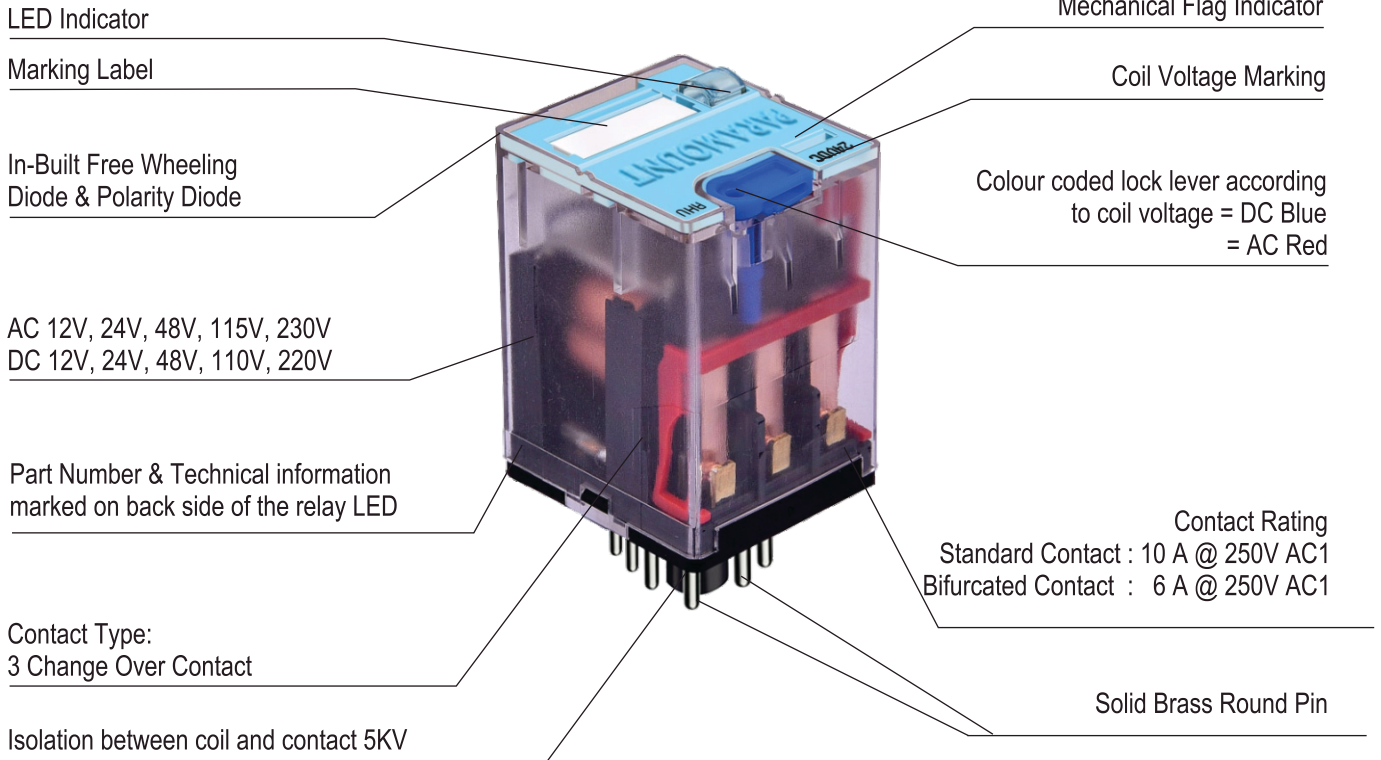

**P3N 3 is a Three Pole Industrial Plug In Relay with all the In-built Mechanical and Electronic Features.**

**OPERATION FOR MANUAL AND LOCKABLE PUSH BUTTON**

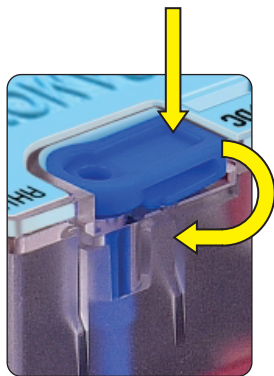

Press the Slot on Top with the help of Screw Driver for Manual Lock

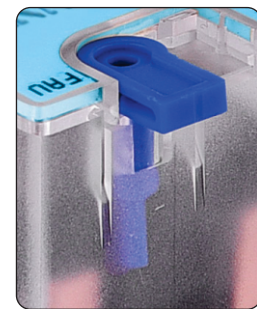

Turn the button 90 Degree for Activating the Lockable Button

Mechanically Lock the Lockable Button in the OFF Position

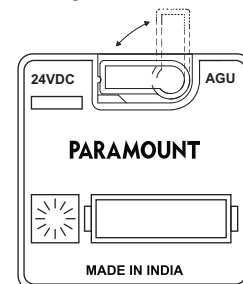
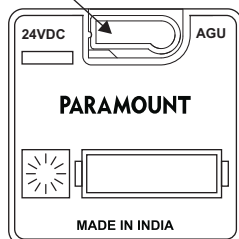

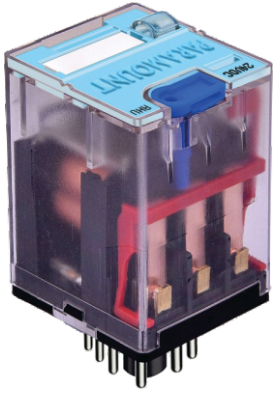

# P3N-3

**General Purpose 3 C/O Contacts**  
**10 A 250V AC1 0.5 A 110V DC1**  
**10 A 30V DC1 0.2 A 220V DC1**

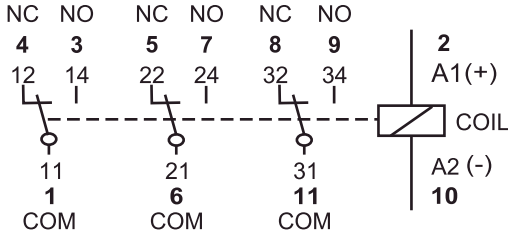

**Graph 1** Electrical life, ops x 10<sup>6</sup>

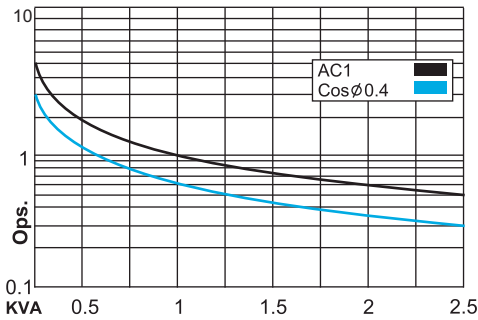

**Graph 2** Max. DC load

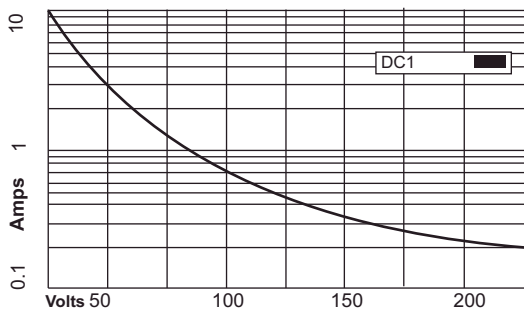

**Dimensions** in mm.

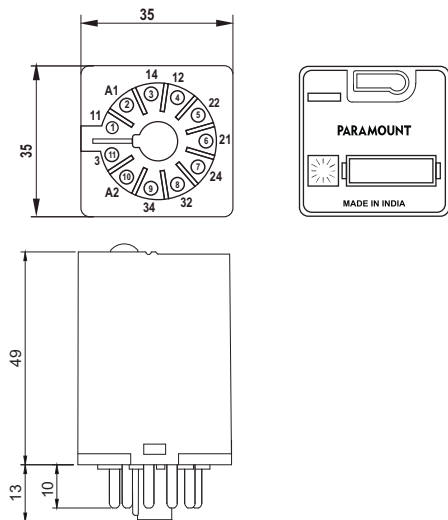

## Contacts

Materials : Standard AgNi  
 Optional 1 AgNi + Au 0.2 μ  
 Optional 2 AgNi + Au 5.0 μ

Max. Switching Current 10A  
 Max. Peak Inrush Current (20 ms) 30A  
 Max. Switching Voltage 250 VAC  
 Switching Power range 0.3 VA (W) to 2500 VAZ  
 Max. Contact Resistance 20m Ω  
 Max. AC Load (Table 1) 2.5 KVA  
 Max. DC Load (See Table 2) -

**Coils (Ohms ± 10% @ 20°C)**  
 Pull-in Voltage ≤ 0.8xUn  
 Drop-out Voltage ≥ 0.1xUn

Nominal Coil Power 1.6 VA (AC / 1.3 W (DC))

VAC	Ohms	VDC	Ohms
6	3.15	6	33
12	13.3	12	115
24	52	24	480
48	240	48	1850
110	1120	110	9000
230	5600	220	29000

## Insulation

Dielectric Strength (1 minute) : open contacts 1500 VAC  
 Between adjacent poles 2000 VAC  
 Between contacts and coil 2500 VAC  
 Insulation Resistance @ 500VDC Min. 200 MΩ  
 Isolation, IEC 61810-5 2.5 KV / 3

## Specifications

Operate / Release & Bounce Time Max. for DC 8+3 / 3.5+8 ms  
 Operate / Release & Bounce Time Max. for AC 9+8 / 12+16 ms  
 Mechanical Life ops. 10 Million AC, 20 Million DC relays  
 Electrical life at Nominal load ≥ 100,000 ops.  
 Operating Frequency at nominal load 1200 / hour  
 Shock Resistance AK : > 10g  
 Vibration Resistance 5g 10.....150 Hz  
 Mounting Direction any  
 Storage -40°C to +85°C  
 Ambient Operating Temperature -40°C to +55°C (for AC relay)  
 Ambient Operating Temperature -40°C to +70°C (for DC relay)  
 Protection Standard IP 40  
 Weight app. 80 g

## Standard Types

**AC : 6, 12, 24, 48, 110, 230**  
 F = Mechanical Flag Indicator  
 P = LED Indicator  
 I = Lockable Push Button  
 R = RC Snubber circuit (115 or 230V)

**DC : 6, 12, 24, 48, 110, 220**  
 F = Mechanical Flag Indicator  
 P = LED  
 I = Lockable Push Button  
 W = Free Wheeling Diode  
 Z = Polarity & Free Wheeling Diode  
 B = AC/DC Bridge Rectifier (24/48V)

P3N-3-F	.... VAC
P3N-3-FP	.... VAC
P3N-3-FPI	.... VAC
P3N-3-FIR	.... VAC
P3N-3-F	.... VDC
P3N-3-FP	.... VDC
P3N-3-FPI	.... VDC
P3N-3-FPIW	.... VDC
P3N-3-FPZI	.... VDC
P3N-3-FPIB	.... VDC

## Suitable Sockets : S11D

## Approvals



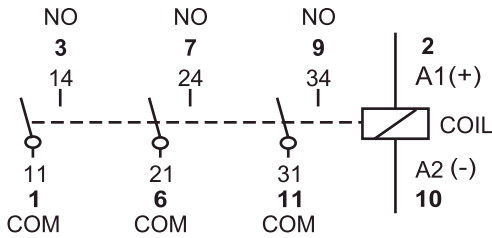

**Graph 1** Electrical life, ops x 10<sup>6</sup>

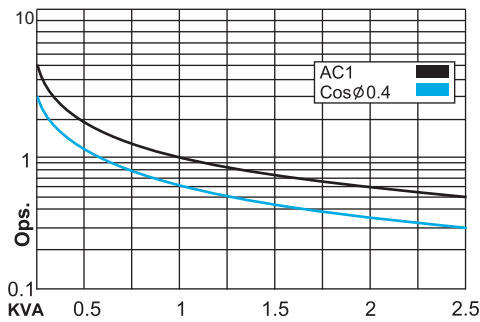

**Graph 2** Max. DC load

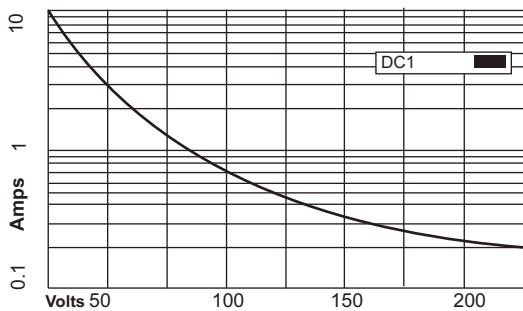

**Dimensions** in mm.

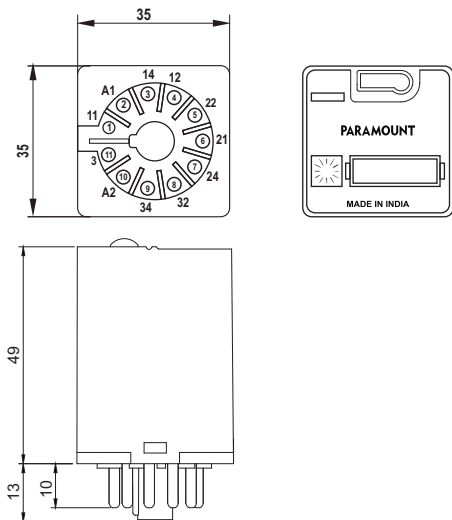

# P3N-3A

**General Purpose 3 N/O Contacts**  
**10 A 250V AC1 0.5 A 110V DC1**  
**10 A 30V DC1 0.2 A 220V DC1**

## Contacts

Materials : Standard AgNi  
Optional 1 AgNi + Au 0.2 μ  
Optional 2 AgNi + Au 5.0 μ

Max. Switching Current 10A  
Max. Peak Inrush Current (20 ms) 30A  
Max. Switching Voltage 250 VAC  
Switching Power range 0.3 VA (W) to 2500 VAZ  
Max. Contact Resistance 20m Ω  
Max. AC Load (Table 1) 2.5 KVA  
Max. DC Load (See Table 2) -

**Coils (Ohms ± 10% @ 20°C)**  
Pull-in Voltage ≤ 0.8xUn  
Drop-out Voltage ≥ 0.1xUn

Nominal Coil Power 1.6 VA (AC / 1.3 W (DC))

VAC	Ohms	VDC	Ohms
6	3.15	6	33
12	13.3	12	115
24	52	24	480
48	240	48	1850
110	1120	110	9000
230	5600	220	29000

## Insulation

Dielectric Strength (1 minute) : open contacts 1500 VAC  
Between adjacent poles 2000 VAC  
Between contacts and coil 2500 VAC  
Insulation Resistance @ 500VDC Min. 200 MΩ  
Isolation, IEC 61810-5 2.5 KV / 3

## Specifications

Operate / Release & Bounce Time Max. for DC 8+3 / 3.5+8 ms  
Operate / Release & Bounce Time Max. for AC 9+8 / 12+16 ms  
Mechanical Life ops. 10 Million AC, 20 Million DC relays  
Electrical life at Nominal load ≥ 100,000 ops.  
Operating Frequency at nominal load 1200 / hour  
Shock Resistance AK : > 10g  
Vibration Resistance 5g 10.....150 Hz  
Mounting Direction any  
Storage -40°C to +85°C  
Ambient Operating Temperature -40°C to +55°C (for AC relay)  
Ambient Operating Temperature -40°C to +70°C (for DC relay)  
Protection Standard IP 40  
Weight app. 80 g

## Standard Types

AC : 6, 12, 24, 48, 110, 230  
F = Mechanical Flag Indicator  
P = LED Indicator  
I = Lockable Push Button  
R = RC Circuit

**P3N-3A-F** .... VAC  
**P3N-3A-FP** .... VAC  
**P3N-3A-FPI** .... VAC  
**P3N-3A-FIR** .... VAC

DC : 6, 12, 24, 48, 110, 220  
F = Mechanical Flag Indicator  
P = LED  
I = Lockable Push Button  
W = Free wheeling Diode  
Z = Polarity & Free Wheeling Diode  
B = AC/DC Bridge Rectifier

**P3N-3A-F** .... VDC  
**P3N-3A-FP** .... VDC  
**P3N-3A-FPI** .... VDC  
**P3N-3A-FPIW** .... VDC  
**P3N-3A-FPZI** .... VDC  
**P3N-3A-FPIB** .... VDC

## Suitable Sockets : S11D-A

## Approvals





# P3N-2.....L



## Latching 2C/O Contact

**10 A 250V AC1 0.5 A 110V DC1**  
**10 A 30V Dc1 0.2 A 220V DC1**

### Contacts

Materials : Standard  
AgNi

Optional 1	AgNi + Au 0.2 μ
Optional 2	AgNi + Au 5.0 μ
Max. Switching Current	10A
Max. Peak Inrush Current (20 ms)	30A
Max. Switching Voltage	250 VAC
Switching Power range	0.3 VA (W) to 2500 VAz
Max. Contact Resistance	20m Ω
Max. AC Load (Table 1)	2.5 KVA
Max. DC Load (See Table 2)	-

### Coils (Ohms ± 10% @ 20°C)

Pull-in Voltage	≤ 0.8xUn
Drop-out Voltage	≥ 0.1xUn

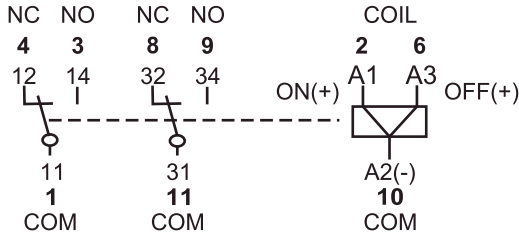

**Graph 1** Electrical life, ops x 10<sup>6</sup>

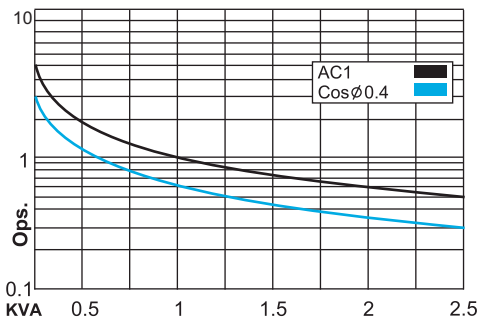

**Graph 2** Max. DC load

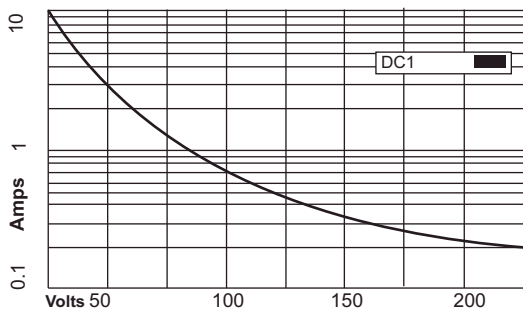

### Dimensions in mm.

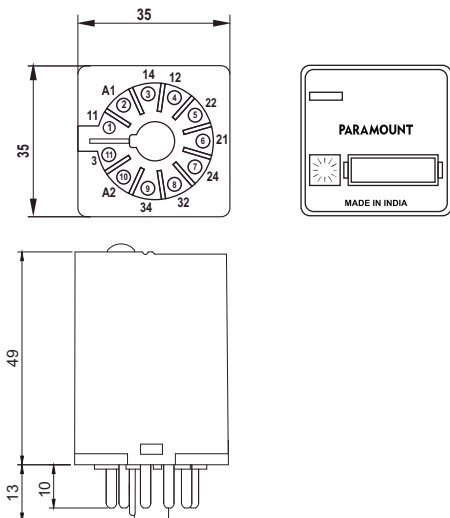

Nominal Coil Power 1.6 VA (AC / 1.3 W (DC))

Coil Voltage	ON Coil Resistance	OFF Coil Resistance	Must Switch ON/OFF Voltage
12 VDC	90 Ω	104 Ω	≤ 9 VDC
24 VDC	360 Ω	430 Ω	≤ 18 VDC
48 VDC	1440 Ω	1720 Ω	≤ 36 VDC
110 VDC	3800 Ω	5000 Ω	≤ 88 VDC
220 VDC	12500 Ω	19700 Ω	≤ 176 VDC

### Insulation

Dielectric Strength (1 minute) : open contacts	1500 VAC
Between adjacent poles	2000 VAC
Between contacts and coil	2500 VAC
Insulation Resistance @ 500VDC Min.	200 MΩ
Isolation, IEC 61810-5	2.5 KV / 3

### Specifications

Operate / Release & Bounce Time Max. for DC	8+3 / 3.5+8 ms
Operate / Release & Bounce Time Max. for AC	9+8 / 12+16 ms
Mechanical Life ops.	10 Million AC, 20 Million DC relays
Electrical life at Nominal load	≥ 100,000 ops.
Operating Frequency at nominal load	1200 / hour
Shock Resistance	AK : > 10g
Vibration Resistance	5g 10.....150 Hz
Mounting Direction	any
Storage	-40°C to +85°C
Ambient Operating Temperature	-40°C to +55°C (for AC relay)
Ambient Operating Temperature	-40°C to +70°C (for DC relay)
Protection Standard	IP 40
Weight	app. 80 g

**Note :- 1) The Input ON & OFF Pulse Width Should be Min. 500ms**  
**2) For Non Standard Coil Voltages. Please Contact Factory**

### Standard Types

DC : 12, 24, 110, 220  
L = Latching Relay

**P3N-2-L .... VDC**

### Suitable Sockets : S11D

### Approvals





# P3N-3T

## 3C/O Bifurcated Contacts

**6 A 250V AC1 0.1 A 110V DC1**

**6 A 30V DC1 Min. Contact Load : 1mA 5VDC 1**

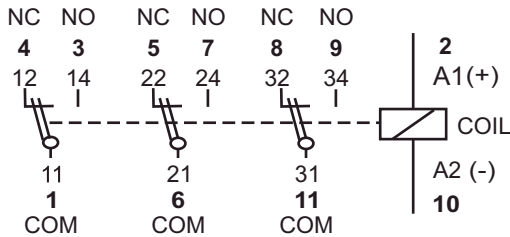

**Graph 1** Electrical life, ops x 10<sup>6</sup>

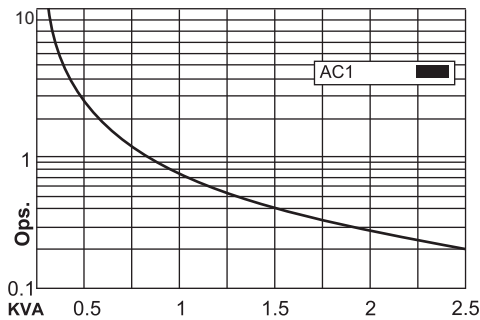

**Graph 2** Max. DC load

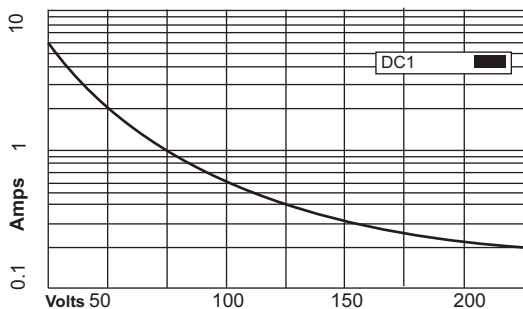

**Dimensions** in mm.

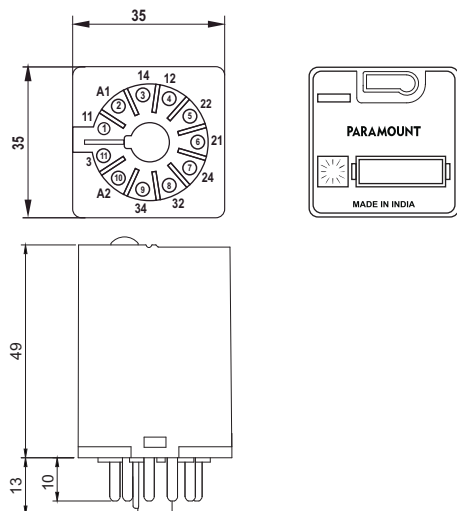

### Contacts

Materials : Standard AgNi  
 Optional 1 AgNi + Au 0.2 μ  
 Optional 2 AgNi + Au 5.0 μ

Max. Switching Current 6A  
 Max. Peak Inrush Current (20 ms) 30A  
 Max. Switching Voltage 250 VAC  
 Switching Power range 0.05 VA (W) to 2500 VAz  
 Max. Contact Resistance 20m Ω  
 Max. AC Load (Table 1) 2.5 KVA  
 Max. DC Load (See Table 2) -

### Coils (Ohms ± @ 20°C)

Pull-in Voltage ≤ 0.8xUn  
 Drop-out Voltage ≥ 0.1xUn  
 Nominal Coil Power 1.6 VA (AC / 1.3 W (DC))

VAC	Ohms	VDC	Ohms
6	3.15	6	33
12	13.3	12	116
24	52	24	480
48	240	48	1850
110	1120	110	9000
230	5600	220	29000

### Insulation

Dielectric Strength (1 minute) : open contacts 1500 VAC  
 Between adjacent poles 2000 VAC  
 Between contacts and coil 2500 VAC  
 Insulation Resistance @ 500VDC Min. 200 MΩ  
 Isolation, IEC 61810-5 2.5 KV / 3

### Specifications

Operate / Release & Bounce Time Max. for DC 8+3 / 3.5+8 ms  
 Operate / Release & Bounce Time Max. for AC 9+8 / 12+16 ms  
 Mechanical Life ops. 10 Million AC, 20 Million DC relays  
 Electrical life at Nominal load ≥ 100,000 ops.  
 Operating Frequency at nominal load 1200 / hour  
 Shock Resistance AK : > 10g  
 Vibration Resistance 5g 10.....150 Hz  
 Mounting Direction any  
 Storage -40°C to +85°C  
 Ambient Operating Temperature -40°C to +55°C (for AC relay)  
 Ambient Operating Temperature -40°C to +70°C (for DC relay)  
 Protection Standard IP 40  
 Weight app. 80 g

### Standard Types

**AC : 6, 12, 24, 48, 110, 230**

**T = Twin Contact**

**F = Mechanical Flag Indicator**

**P = LED Indicator**

**I = Lockable Push Button**

**R = RC Circuit**

**P3N-3T-F .... VAC**  
**P3N-3T-FP .... VAC**  
**P3N-3T-FPI .... VAC**  
**P3N-3T-FIR .... VAC**

**DC : 6, 12, 24, 48, 110, 220**

**F = Mechanical Flag Indicator**

**P = LED**

**I = Lockable Push Button**

**Z = Polarity & Free Wheeling Diode**

**B = AC/DC Bridge Rectifier**

**P3N-3T-F .... VDC**  
**P3N-3T-FP .... VDC**  
**P3N-3T-FPI .... VDC**  
**P3N-3T-FPZI .... VDC**  
**P3N-3T-FPIB .... VDC**

### Suitable Sockets : S11D

### Approvals





# P3N-3....H

## Long Life Relay 3C/O Contact

**10 A 250V AC1 0.5 A 110V DC1**  
**10 A 30V DC1 0.2 A 220V DC1**

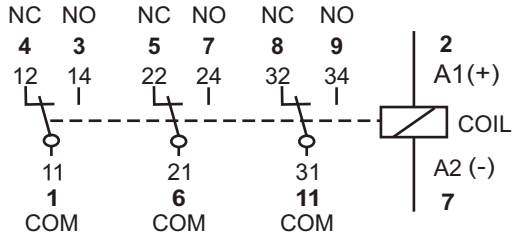

**Graph 1** Electrical life, ops x 10<sup>6</sup>

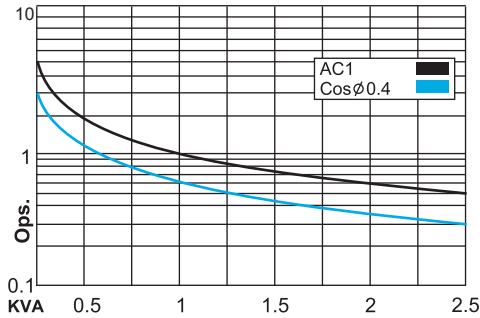

**Graph 2** Max. DC load

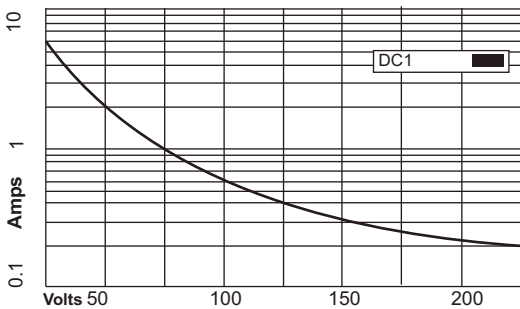

**Dimensions** in mm.

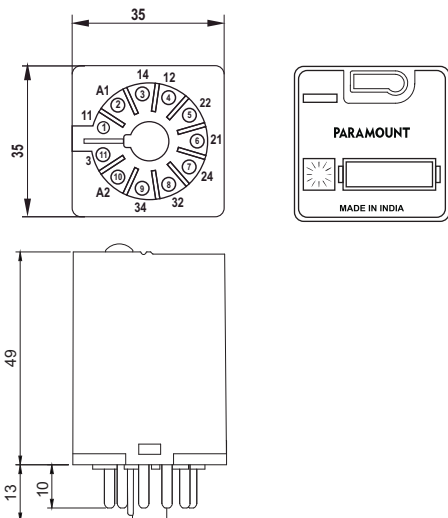

### Contacts

Materials : Standard AgNi  
Optional 1 AgNi + Au 0.2 μ  
Optional 2 AgNi + Au 5.0 μ

Max. Switching Current 10A  
Max. Peak Inrush Current (20 ms) 30A  
Max. Switching Voltage 250 VAC  
Switching Power range 03 VA (W) to 2500 Waz  
Max. Contact Resistance 20m Ω  
Max. AC Load (Table 1) 2.5 KVA  
Max. DC Load (See Table 2) -

### Coils (Ohms ± @ 20°C)

Pull-in Voltage ≤ 0.8xUn  
Drop-out Voltage ≥ 0.1xUn  
Nominal Coil Power 1.6 VA (AC / 1.3 W (DC))

VAC	Ohms	VDC	Ohms
6	3.15	6	33
12	13.3	12	115
24	52	24	480
48	240	48	1850
110	1120	110	9000
230	5600	220	29000

### Insulation

Dielectric Strength (1 minute) : open contacts 1500 VAC  
Between adjacent poles 2000 VAC  
Between contacts and coil 2500 VAC  
Insulation Resistance @ 500VDC Min. 200 MΩ  
Isolation, IEC 61810-5 2.5 KV / 3

### Specifications

Operate / Release & Bounce Time Max. for DC 8+3 / 3.5+8 ms  
Operate / Release & Bounce Time Max. for AC 9+8 / 12+16 ms  
Mechanical Life ops. 10 Million AC, 20 Million DC relays  
Electrical life at Nominal load ≥ 700,000 ops.  
Operating Frequency at nominal load 1200 / hour  
Shock Resistance AK : > 10g  
Vibration Resistance 5g 10.....150 Hz  
Mounting Direction any  
Storage -40°C to +85°C  
Ambient Operating Temperature -40°C to +55°C (for AC relay)  
Ambient Operating Temperature -40°C to +70°C (for DC relay)  
Protection Standard IP 40  
Weight app. 80 g

### Standard Types

**AC : 6, 12, 24, 48, 110, 230**

**H = Long Life Relay**

**F = Mechanical Flag Indicator**

**P = LED Indicator**

**I = Lockable Push Button**

**R = RC Circuit**

**DC : 6, 12, 24, 48, 110, 220**

**F = Mechanical Flag Indicator**

**P = LED**

**I = Lockable Push Button**

**Z = Polarity & Free Wheeling Diode**

**B = AC/DC Bridge Rectifier**

**P3N-3-F-H .... VAC**

**P3N-3-FP-H .... VAC**

**P3N-3-FPI-H .... VAC**

**P3N-3-FIR-H .... VAC**

**P3-3-F-H .... VDC**

**P3N-3-FP-H .... VDC**

**P3N-3-FPI-H .... VDC**

**P3N-3-FPZI-H .... VDC**

**P3N-3-FPIB-H .... VDC**

### Suitable Sockets : S11D

### Approvals





# P3N-3....E



**6Amps Relays - 3C/O Contact**  
**6 A 250V AC1 0.5 A 110V DC1**  
**6 A 30V DC1 0.2 A 220V DC1**

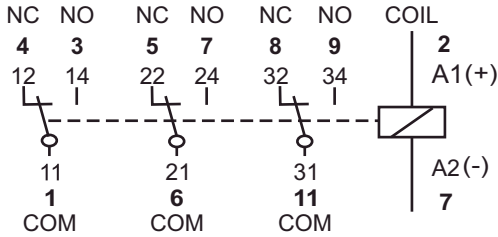

**Graph 1** Electrical life, ops x 10<sup>6</sup>

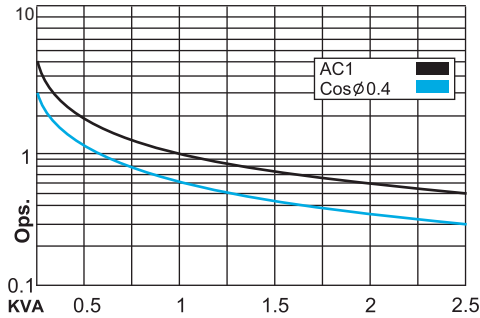

**Graph 2** Max. DC load

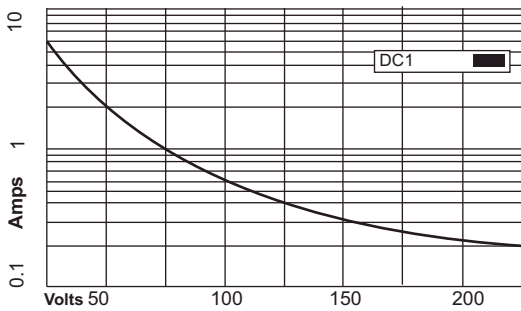

**Dimensions** in mm.

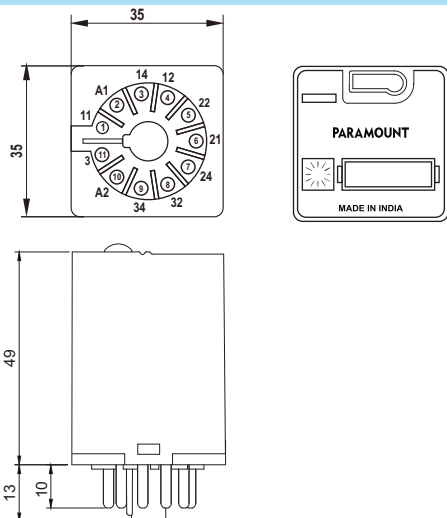

## Contacts

Materials : Standard  
 Optional 1  
 Optional 2

	AgNi
	AgNi + Au 0.2 μ
	AgNi + Au 5.0 μ
Max. Switching Current	6A
Max. Peak Inrush Current (20 ms)	30A
Max. Switching Voltage	250 VAC
Switching Power range	0.3 VA (W) to 2500 VAz
Max. Contact Resistance	20m Ω
Max. AC Load (Table 1)	2.5 KVA
Max. DC Load (See Table 2)	-

## Coils (Ohms ± @ 20°C)

Pull-in Voltage ≤ 0.8xUn  
 Drop-out Voltage ≥ 0.1xUn  
 Nominal Coil Power 1.6 VA (AC / 1.3 W (DC))

VAC	Ohms	VDC	Ohms
6	3.15	6	33
12	13.3	12	115
24	52	24	480
48	240	48	1850
110	1120	110	9000
230	5600	220	29000

## Insulation

Dielectric Strength (1 minute) : open contacts 1500 VAC  
 Between adjacent poles 2000 VAC  
 Between contacts and coil 2500 VAC  
 Insulation Resistance @ 500VDC Min. 200 MΩ  
 Isolation, IEC 61810-5 2.5 KV / 3

## Specifications

Operate / Release & Bounce Time Max. for DC 8+3 / 3.5+8 ms  
 Operate / Release & Bounce Time Max. for AC 9+8 / 12+16 ms  
 Mechanical Life ops. 10 Million AC, 20 Million DC relays  
 Electrical life at Nominal load ≥ 100,000 ops.  
 Operating Frequency at nominal load 1200 / hour  
 Shock Resistance AK : > 10g  
 Vibration Resistance 5g 10.....150 Hz  
 Mounting Direction any  
 Storage -40°C to +85°C  
 Ambient Operating Temperature -40°C to +55°C (for AC relay)  
 Ambient Operating Temperature -40°C to +70°C (for DC relay)  
 Protection Standard IP 40  
 Weight app. 80 g

## Standard Types

**AC : 6, 12, 24, 48, 110, 230**

**E = 6 Amps Relay**

F = Mechanical Flag Indicator

P = LED Indicator

I = Lockable Push Button

R = RC Circuit

**DC : 6, 12, 24, 48, 110, 220**

F = Mechanical Flag Indicator

P = LED

I = Lockable Push Button

Z = Polarity & Free Wheeling Diode

B = AC/DC Bridge Rectifier

**P3N-3-F-E .... VAC**

**P3N-3-FP-E .... VAC**

**P3N-3-FPI-E .... VAC**

**P3N-3-FIR-E .... VAC**

**P3N-3-F-E .... VDC**

**P3N-3-FP-E .... VDC**

**P3N-3-FPI-E .... VDC**

**P3N-3-FPZI-E .... VDC**

**P3N-3-FPIB-E .... VDC**

## Suitable Sockets : S11D-E

## Approvals



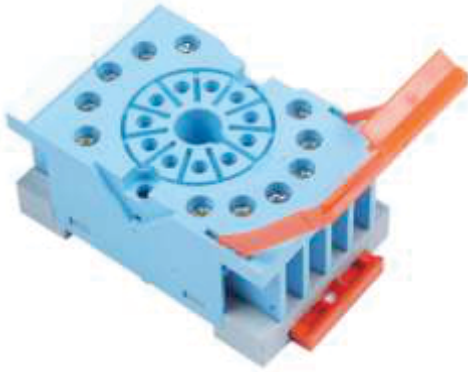

# S11D

Only  
**38 mm**  
WIDE

**Socket for P3 3C/O Relay  
DIN Rail or Panel Mountable**

## Wiring diagram

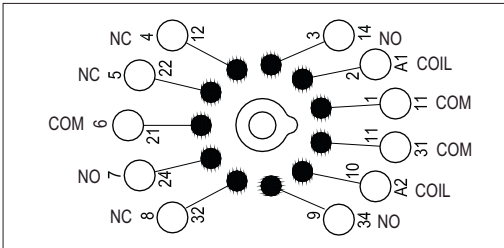

## Specifications

Poles 3 Change Over Contact (11pins)  
Nominal load : 10A / 250V

**Insulation** : Di-electric strength, 1minute

Between contact and coil	2.5 KV
Between all terminals and DIN Rail	2.5 KV
Between adjacent terminals	2.5 KV

Max. screw torque	0.5 Nm
Screw dimensions	M3, Pozi

**Wire in-lets capacity :**

Solid Wire	4sq mm or 2 x 2.25 mm
Multi core	22 14 AWG
Ferrule tip terminals	4mmsq

Weight Approx.	47 gms.
----------------	---------

## Dimensions in mm

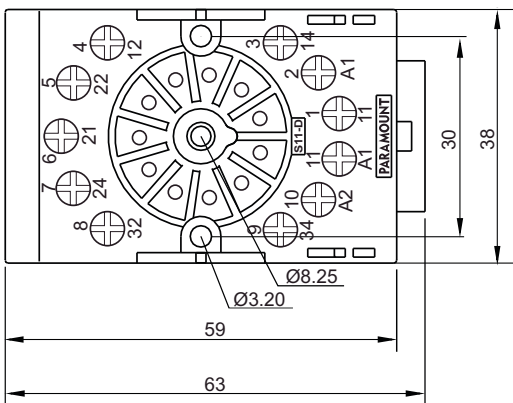
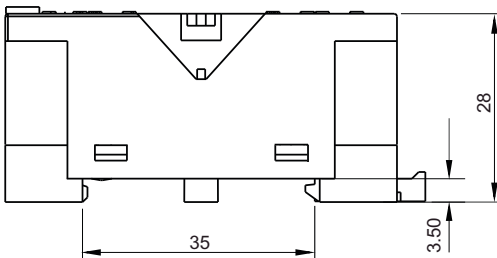

## Other Aspects

DIN Rail / Panel Mountable  
EN / DIN Sequential Numbering according to EN 60947 & IEC 61810  
Integrated Relay Hold Down Clip  
Removable White Marking Label  
Hard Brass Tin Plated Terminals  
Brass Tin Plated Screws

**Suitable Relays : P3N-3**

Approvals



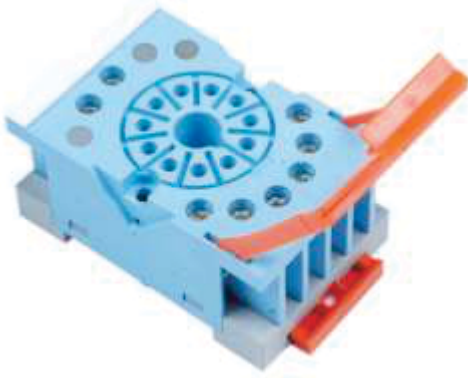

# S11D-A

Only  
**38 mm**  
WIDE

**Socket for P3 3N/O Relay  
DIN Rail or Panel Mountable**

## Wiring diagram

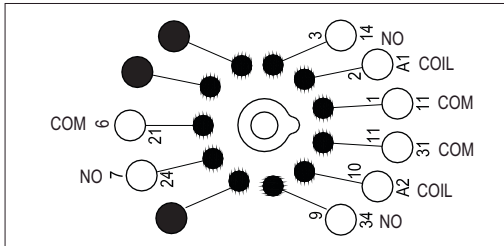

## Specifications

Poles 3 Normally Open Contact (11pins)  
Nominal load : 10A / 250V

**Insulation** : Di-electric strength, 1minute

Between contact and coil	2.5 KV
Between all terminals and DIN Rail	2.5 KV
Between adjacent terminals	2.5 KV

Max. screw torque	0.5 Nm
Screw dimensions	M3, Pozi

**Wire in-lets capacity :**

Solid Wire	4sq mm or 2 x 2.25 mm
Multi core	22 14 AWG
Ferrule tip terminals	4mmsq

Weight Approx.	47 gms.
----------------	---------

## Dimensions

in mm

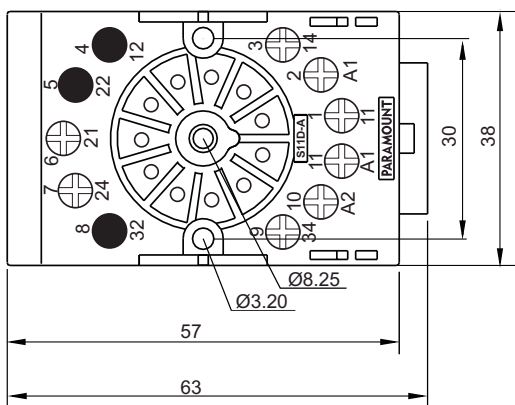
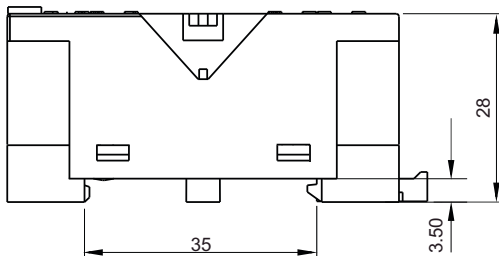

## Other Aspects

DIN Rail / Panel Mountable  
EN / DIN Sequential Numbering according to  
EN 60947 & IEC 61810  
Integrated Relay Hold Down Clip  
Removable White Marking Label  
Hard Brass Tin Plated Terminals  
Brass Tin Plated Screws

**Suitable Relays : P3N-3A**

**Approvals**



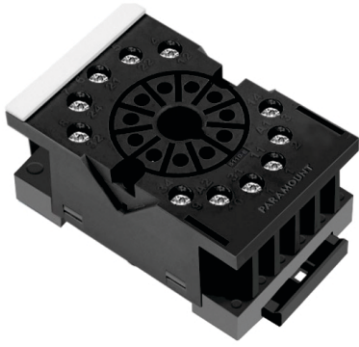

## S11D-E (NON UL)

Only  
**38 mm**  
WIDE

**Socket for P3 3C/O Relay  
DIN Rail or Panel Mountable**

### Wiring diagram

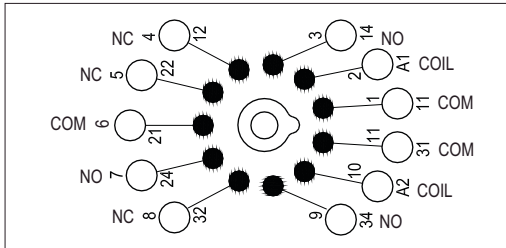

### Specifications

Poles 3 Change Over Contact (11pins)  
Nominal load : 10A / 250V

**Insulation** : Di-electric strength, 1minute

Between contact and coil	2.5 KV
Between all terminals and DIN Rail	2.5 KV
Between adjacent terminals	2.5 KV

Max. screw torque	0.5 Nm
Screw dimensions	M3, Pozi

**Wire in-lets capacity :**

Solid Wire	4sq mm or 2 x 2.25 mm
Multi core	22 14 AWG
Ferrule tip terminals	4mmsq

Weight Approx.	47 gms.
----------------	---------

### Dimensions in mm

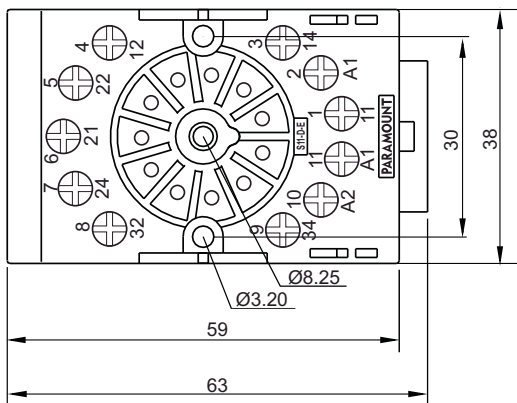
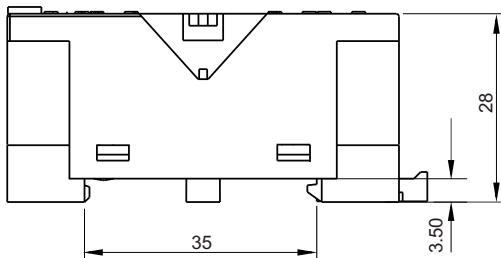

### Other Aspects

DIN Rail / Panel Mountable  
EN / DIN Sequential Numbering according to EN 60947 & IEC 61810  
Integrated Relay Hold Down Clip  
Removable White Marking Label  
Hard Brass Tin Plated Terminals  
Brass Tin Plated Screws

**Suitable Relays : P3N-3E1, P3N-2L-E1**

Approvals



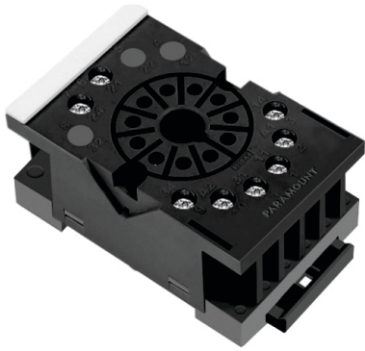

# S11D-A-E (NON UL)

Only  
**38 mm**  
WIDE

**Socket for P3 3N/O Relay  
DIN Rail or Panel Mountable**

## Wiring diagram

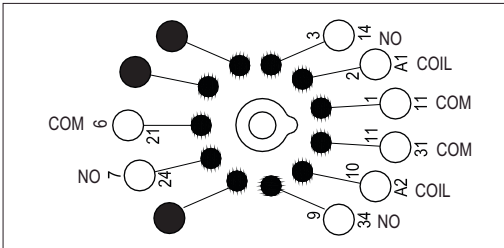

## Specifications

Poles 3 Normally Open Contact (11pins)  
Nominal load : 10A / 250V

**Insulation** : Di-electric strength, 1minute

Between contact and coil	2.5 KV
Between all terminals and DIN Rail	2.5 KV
Between adjacent terminals	2.5 KV

Max. screw torque	0.5 Nm
Screw dimensions	M3, Pozi

**Wire in-lets capacity :**

Solid Wire	4sq mm or 2 x 2.25 mm
Multi core	22 14 AWG
Ferrule tip terminals	4mmsq

Weight Approx.	47 gms.
----------------	---------

## Dimensions in mm

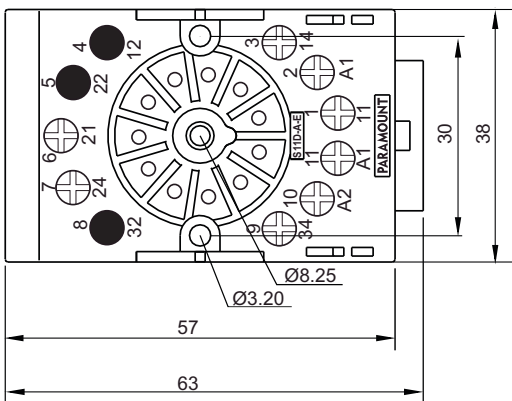
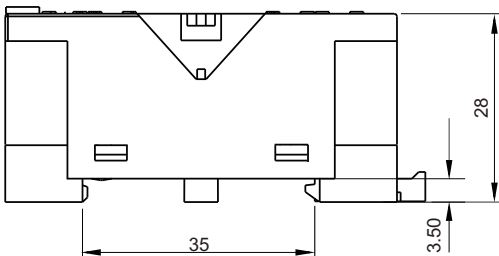

## Other Aspects

DIN Rail / Panel Mountable  
EN / DIN Sequential Numbering according to  
EN 60947 & IEC 61810  
Integrated Relay Hold Down Clip  
Removable White Marking Label  
Hard Brass Tin Plated Terminals  
Brass Tin Plated Screws

**Suitable Relays : P3N-3A-E1**

**Approvals**



### Ordering Information for Relays

P3N--------  
1 2 3 4 5 6 7 8

#### 1. Relay Type

Blank : General Purpose / Standard ?

#### 2. Contact Form

3 : TPDT (3C/O)  
3A : 3 NO

#### 3. Contact Type

Blank : Single  
T : Twin Contact

#### 4. Features

F : Mechanical operation Indicator  
P : LED Indicator  
Z : Free Wheeling + Polarity Diode  
C : Push Button  
I : Lockable Push Button & Manual Push Button  
B : Bridge Rectifier  
R : RC circuit  
W : Free Wheeling Diode  
S : Sensitive Relays

#### 5. Special Types

Blank : Standard  
L : Latching (11 pin)  
H : Long Life (700,000 operations)

#### 6. Contact Material

Blank : AgNi  
1. : AgNi + Au 0.2  $\mu$   
2. : AgNi + Au 5.0  $\mu$

#### 7. Blank : UL Approved (10 Amps)

E : UL Approved (6 Amps)  
E1 : NON UL (10 Amps)  
E2 : NON UL (6 Amps)

#### 8. Rated Coil Voltage

6 / 12 / 24 / 48 / 110 / 220 - VDC  
6 / 12 / 24 / 48 / 115 / 230 - VAC

#### NOTE:-

- For Current coil please specify AC/DC coil current in place of coil voltage
- Standard Frequency is 50 Hz for AC coil, for other frequency please specify frequency after coil voltage

### Ordering Information for Sockets for P3N-3 Relays

<b>S11D</b>	Din Rail Mountable Socket	(UL Approved)	For General purpose 3 CO Relays
<b>S11D-A</b>	Din Rail Mountable Socket	(UL Approved)	For General purpose 3 NO Relays
<b>S11D-E</b>	Din Rail Mountable Socket	(NON UL)	For General purpose 3 CO Relays
<b>S11D-A-E</b>	Din Rail Mountable Socket	(NON UL)	For General purpose 3 NO Relays