

**Catalogue  
Series P10**

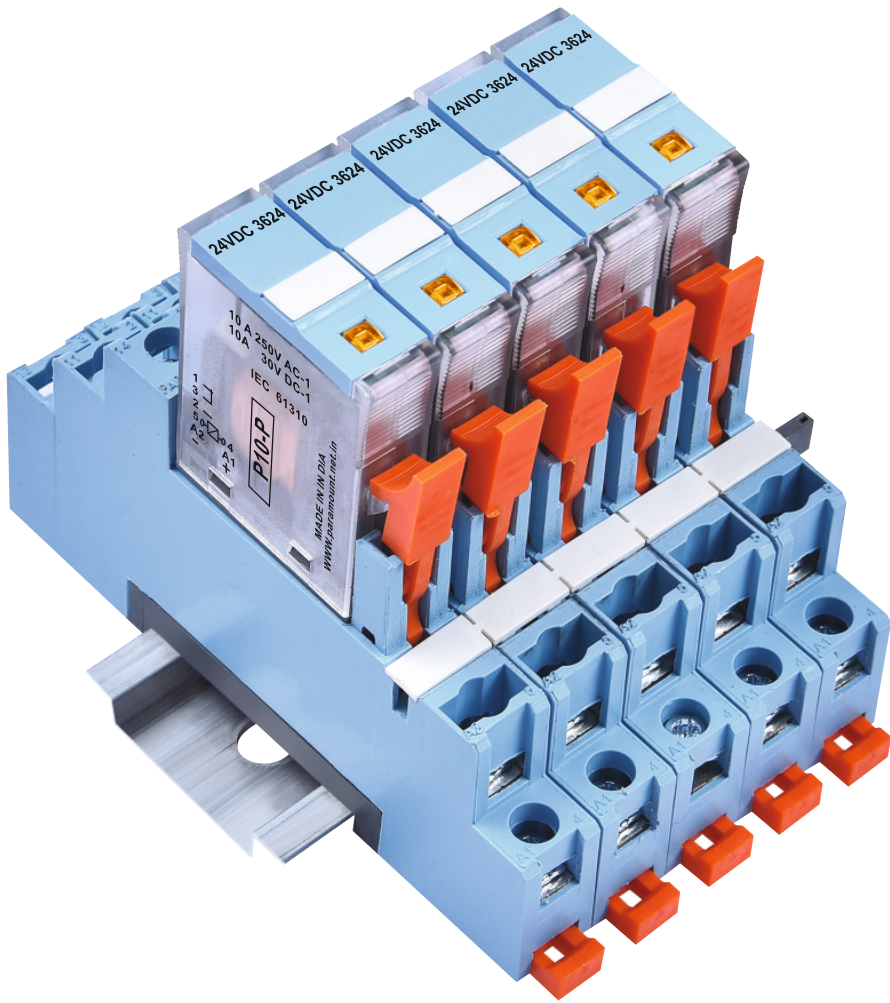

**World's  Most Compact Plug In Relay  
with Built-in Electronics**

Benefits of the new **Compact Plus** system

**P10 Relay (10mm width)**

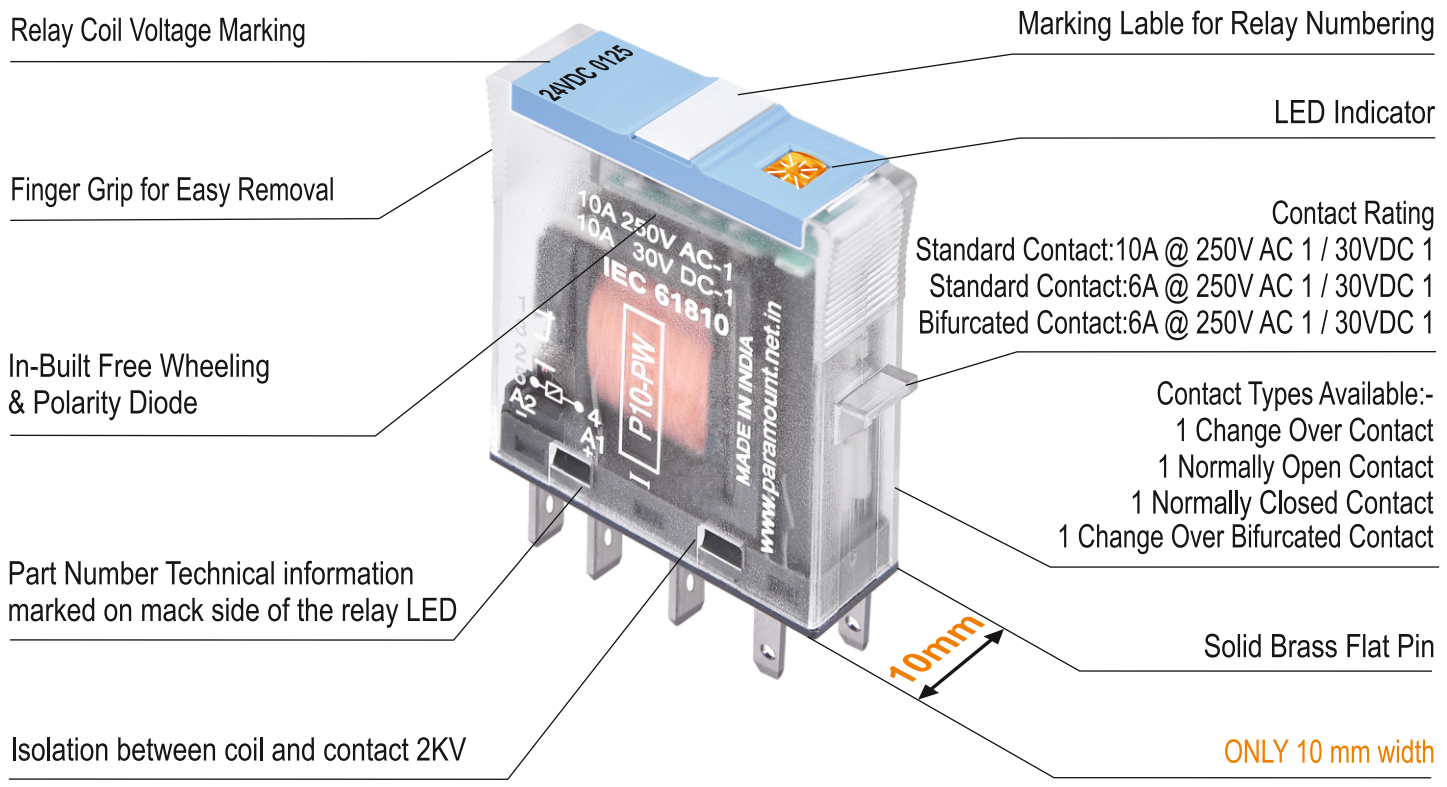

**P10 is a One Pole Compact Industrial Plug in Relay with all the In-built Electronic Features.**

Benefits of the new **Compact Plus** system

**P10 Relay (width 10 mm Only)**  
**S10LD Socket (width 11 mm Only)**

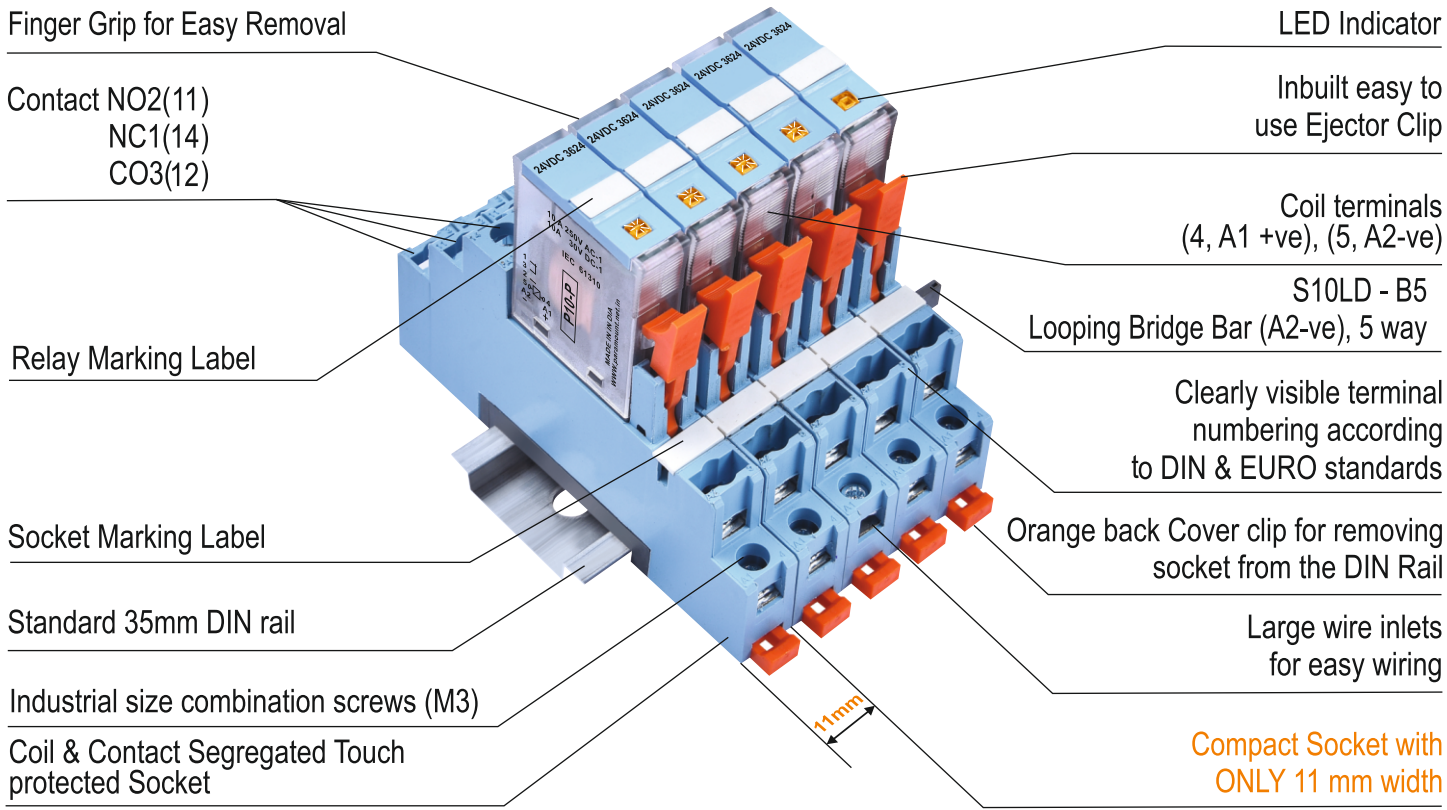

**P10 Relay with S10LD socket with 5 way S10LD-B5 bridges**

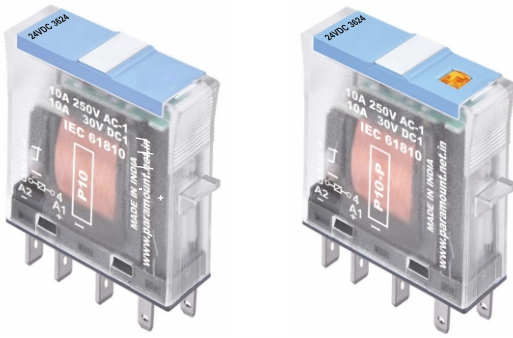

# P10



## One Pole, Change-Over Contact

**10A 250V AC1 0.2A 220V DC1**  
**10A 30V DC1 0.5A 110V DC1**

### Pin Configuration

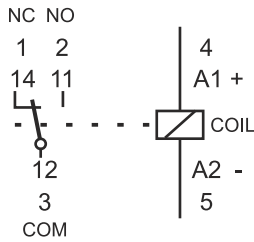

### Graph 1 Electrical life, ops x 10<sup>6</sup>

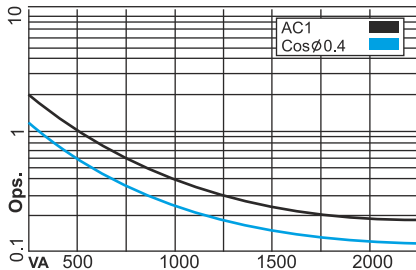

### Graph 2 Max. DC load

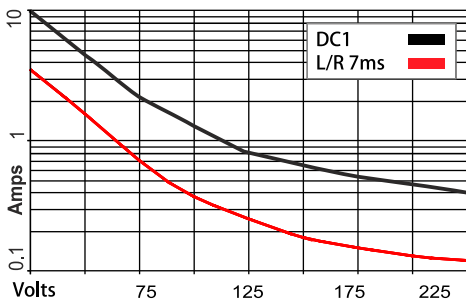

### Dimensions in mm.

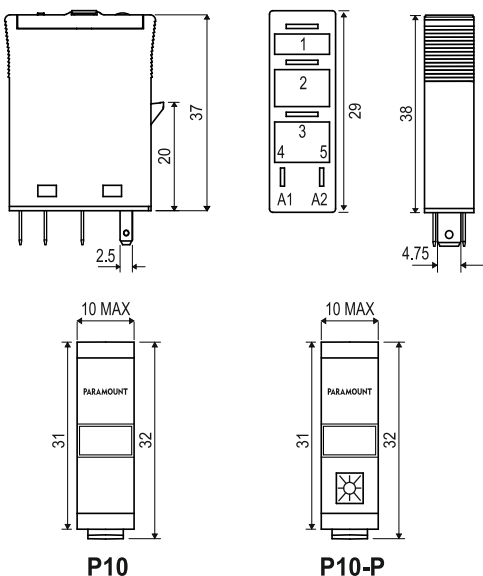

### Contacts

Materials : Standard AgNi  
Optional, code 1 AgNi + Au 0.2μ  
Optional, code 2 AgNi + Au 5.0μ  
Max. switching current 10 A  
Max. Peak inrush current (20 ms.) 30 A  
Max. Switching voltage 250 V  
Max. AC load (Graph 1) 2.5 KVA  
Max. DC load See Graph 2\*

### Coils (Ohms ± 10% @ 20°C)

Pull-in voltage ≤ 0.8 x Un  
Drop-out voltage ≥ 0.1 x Un  
Nominal Coil Power 0.7 VA (AC) / 0.5 W (DC)

VAC	Ω	VDC	Ω
110	8,700	12	290
230	33,300	24	810
		60	5,000

### Insulation

Dielectric strength (1 minute) :  
Open contacts 1 KV  
Between Contacts & Coil 2 KV  
Insulation resistance at 500VDC 100MΩ

### Specifications

Operate Time + Bounce Time 15ms max  
Release Time + Bounce Time 15ms max  
Ambient Temperature -40°C (no ice)... +70°C  
Mechanical life ops. 20 Million DC relays  
Electrical life at nominal load > 100,000 ops.  
Operating frequency at nominal load 1,200 / hour  
Protection (Graph 1) IP40 / RT1  
Weight Approx 18 gms.

### Standard types

**AC 50 Hz : 110, 230**  
P = LED **P10-P ...VAC**  
R = R/C (110/230V) (Built in the Socket) **P10-PR ...VAC**  
V = Variastor (Built in the Socket) **P10-PV ...VAC**

**DC : 12, 24, 60**  
P = LED **P10-P ...VDC**  
W = Free-Wheeling Diodes **P10-PW ...VDC**  
Z = Polarity & Free-Wheeling Diodes **P10-PZ ...VDC**  
B = AC/DC Bridge Rectifier (24/48V) (Built in the Socket) **P10-PB ...VDC/AC**

### Suitable Sockets : S10LD, S10LD-E, S10P, S10EP

### Approvals

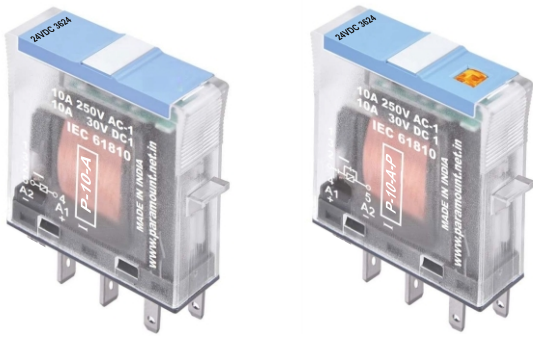

# P10-A

**One Pole, Normally Open Contact**

**10A 250V AC1 0.2A 220V DC1**  
**10A 30V DC1 0.5A 110V DC1**

## Pin Configuration

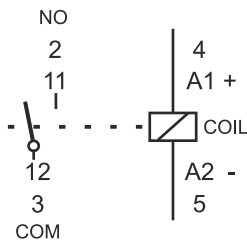

## Graph 1 Electrical life, ops x 10<sup>6</sup>

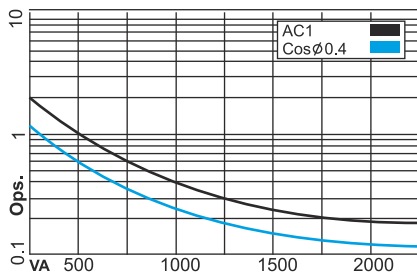

## Graph 2 Max. DC load

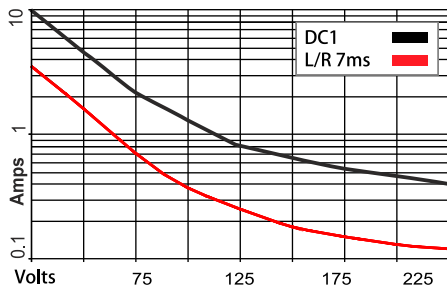

## Dimensions in mm.

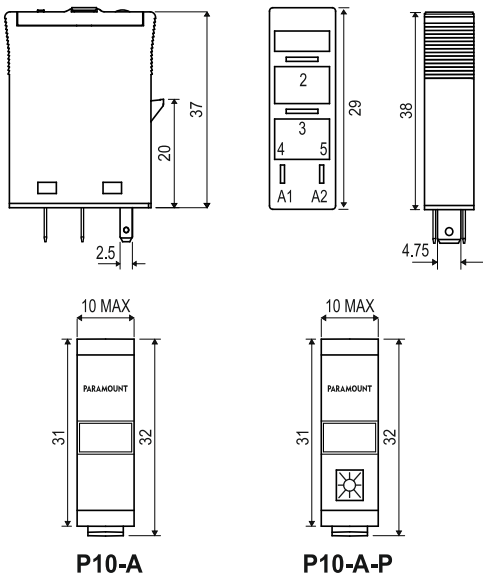

## Contacts

Materials : Standard	AgNi
Optional, code 1	AgNi + Au 0.2μ
Optional, code 2	AgNi + Au 5.0μ
Max. switching current	10 A
Max. Peak inrush current (20 ms.)	15 A
Max. Switching voltage	250 V
Max. AC load (Graph 1)	2.5 KVA
Max. DC load	See Graph 2*

## Coils (Ohms ± 10% @ 20°C)

Pull-in voltage	≤ 0.8 x Un
Drop-out voltage	≥ 0.1 x Un
Nominal Coil Power	0.7 VA (AC) / 0.5 W (DC)

VAC	Ω	VDC	Ω
110	8,700	12	290
230	33,300	24	810
		60	5,000

## Insulation

Dielectric strength (1 minute) :	
Open contacts	1 KV
Between Contacts & Coil	2 KV
Insulation resistance at 500VDC	100MΩ

## Specifications

Operate Time + Bounce Time	15ms max
Release Time + Bounce Time	15ms max
Ambient Temperature	-40°C (no ice)... +70°C
Mechanical life ops.	20 Million DC relays
Electrical life at nominal load	> 100,000 ops.
Operating frequency at nominal load	1,200 / hour
Protection (Graph 1)	IP40 / RT1
Weight Approx	18 gms.

## Standard types

<b>AC 50 Hz : 110, 230</b>	
P = LED	<b>P10-A-P ...VAC</b>
R = R/C (110/230V) (Built in the Socket)	<b>P10-A-PR ...VAC</b>
V = Variastor (Built in the Socket)	<b>P10-A-PV ...VAC</b>
<b>DC : 12, 24, 60</b>	
P = LED	<b>P10-A-P ...VDC</b>
W = Free-Wheeling Diodes	<b>P10-A-PW ...VDC</b>
Z = Polarity & Free-Wheeling Diodes	<b>P10-A-PZ ...VDC</b>
B = AC/DC Bridge Rectifier (24/48V) (Built in the Socket)	<b>P10-A-PB ...VDC/AC</b>

## Suitable Sockets : S10LD-A, S10LD-A-E, S10P, S10EP

## Approvals

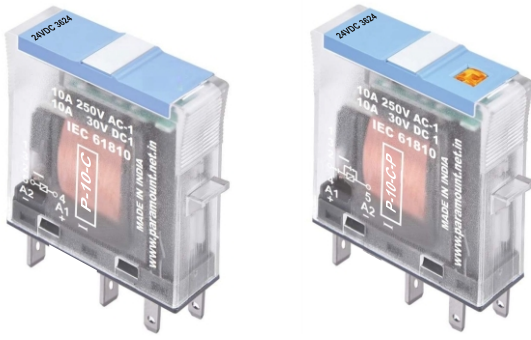

# P10-C



**One Pole, Normally Closed Contact**

**10A 250V AC1 0.2A 220V DC1**  
**10A 30V DC1 0.5A 110V DC1**

## Pin Configuration

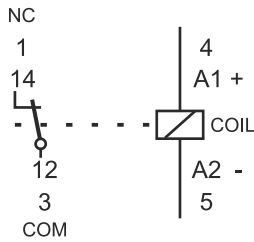

## Graph 1 Electrical life, ops x 10<sup>6</sup>

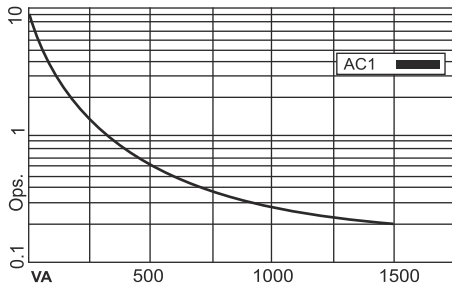

## Graph 2 Max. DC load

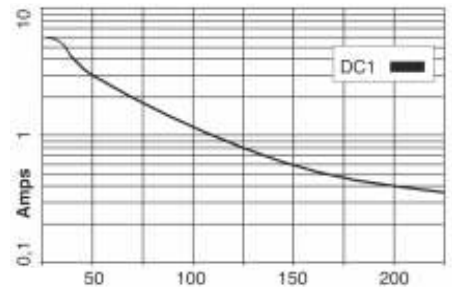

## Dimensions in mm.

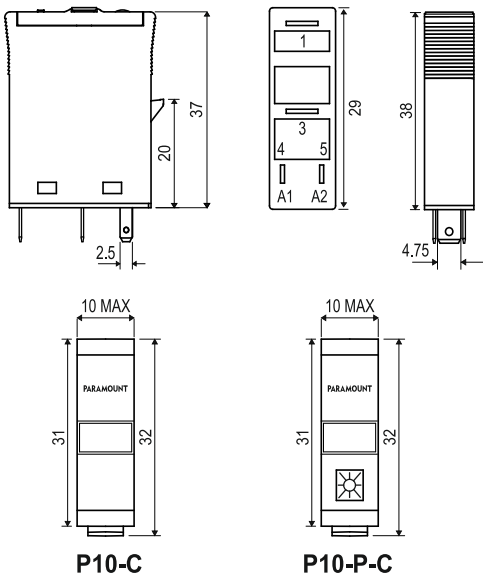

## Contacts

Materials : Standard	AgNi
Optional, code 1	AgNi + Au 0.2μ
Optional, code 2	AgNi + Au 5.0μ
Max. switching current	10 A
Max. Peak inrush current (20 ms.)	30 A
Max. Switching voltage	250 V
Max. AC load (Graph 1)	2.5 KVA
Max. DC load	See Graph 2*

## Coils (Ohms ± 10% @ 20°C)

Pull-in voltage	≤ 0.8 x Un
Drop-out voltage	≥ 0.1 x Un
Nominal Coil Power	0.7 VA (AC) / 0.5 W (DC)

VAC	Ω	VDC	Ω
110	8,700	12	290
230	33,300	24	810
		60	5,000

## Insulation

Dielectric strength (1 minute) :	
Open contacts	1 KV
Between Contacts & Coil	2 KV
Insulation resistance at 500VDC	100MΩ

## Specifications

Operate Time + Bounce Time	15ms max
Release Time + Bounce Time	15ms max
Ambient Temperature	-40°C (no ice)... +70°C
Mechanical life ops.	20 Million DC relays
Electrical life at nominal load	> 100,000 ops.
Operating frequency at nominal load	1,200 / hour
Protection (Graph 1)	IP40 / RT1
Weight Approx	18 gms.

## Standard types

<b>AC 50 Hz : 110, 230</b>	
P = LED	<b>P10-C-P ...VAC</b>
R = R/C (110/230V) (Built in the Socket)	<b>P10-C-PR ...VAC</b>
V = Variastor (Built in the Socket)	<b>P10-C-PV ...VAC</b>

<b>DC : 12, 24, 60</b>	
P = LED	<b>P10-C-P ...VDC</b>
W = Free-Wheeling Diodes	<b>P10-C-PW ...VDC</b>
Z = Polarity & Free-Wheeling Diodes	<b>P10-C-PZ ...VDC</b>
B = AC/DC Bridge Rectifier (24/48V) (Built in the Socket)	<b>P10-C-PB ...VDC/AC</b>

## Suitable Sockets : S10LD-C, S10LD-C-E, S10P, S10EP

## Approvals

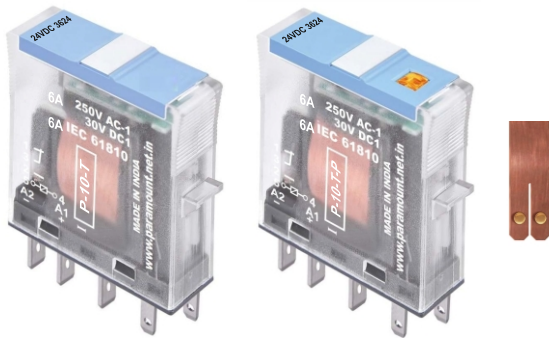

# P10-T



## One Pole, Change-Over Twin Contact

**6A 250V AC1 0.2A 220V DC1**  
**6A 30V DC1 0.5A 110V DC1**

### Pin Configuration

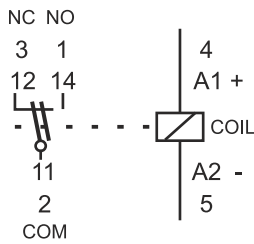

### Contacts

Materials : Standard	AgNi
Optional, code 1	AgNi + Au 0.2μ
Optional, code 2	AgNi + Au 5.0μ
Max. switching current	6 A
Max. Peak inrush current (20 ms.)	15 A
Max. Switching voltage	250 V
Max. AC load (Graph 1)	2.5 KVA
Max. DC load	See Graph 2*

### Graph 1 Electrical life, ops x 10<sup>6</sup>

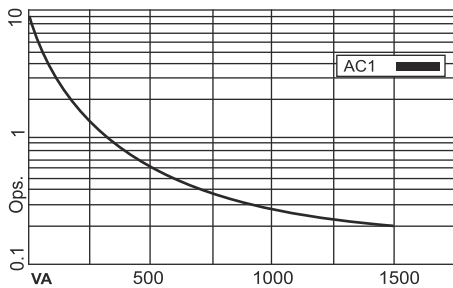

### Coils (Ohms ± 10% @ 20°C)

Pull-in voltage	≤ 0.8 x Un
Drop-out voltage	≥ 0.1 x Un
Nominal Coil Power	0.7 VA (AC) / 0.5 W (DC)

VAC	Ω	VDC	Ω
110	8,700	12	290
230	33,300	24	810
		60	5,000

### Graph 2 Max. DC load

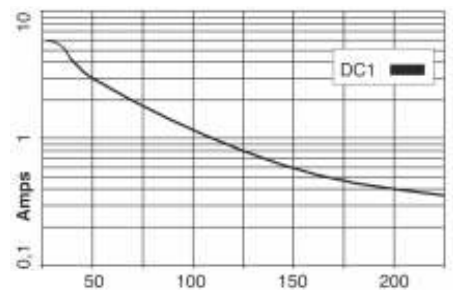

### Insulation

Dielectric strength (1 minute) :	
Open contacts	1 KV
Between Contacts & Coil	2 KV
Insulation resistance at 500VDC	100MΩ

### Specifications

Operate Time + Bounce Time	15ms max
Release Time + Bounce Time	15ms max
Ambient Temperature	-40°C (no ice)... +70°C
Mechanical life ops.	20 Million DC relays
Electrical life at nominal load	> 100,000 ops.
Operating frequency at nominal load	1,200 / hour
Protection (Graph 1)	IP40 / RT1
Weight Approx	18 gms.

### Dimensions in mm.

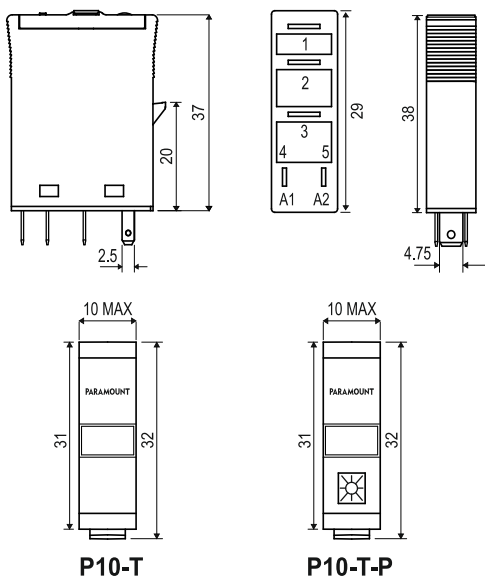

### Standard types

<b>AC 50 Hz : 110, 230</b>	
P = LED	<b>P10-T-P ...VAC</b>
R = R/C (110/230V) (Built in the Socket)	<b>P10-T-PR ...VAC</b>
V = Variastor (Built in the Socket)	<b>P10-T-PV ...VAC</b>
<b>DC : 12, 24, 60</b>	
P = LED	<b>P10-T-P ...VDC</b>
W = Free-Wheeling Diodes	<b>P10-T-PW ...VDC</b>
Z = Polarity & Free-Wheeling Diodes	<b>P10-T-PZ ...VDC</b>
B = AC/DC Bridge Rectifier (24/48V) (Built in the Socket)	<b>P10-T-PB ...VDC/AC</b>

### Suitable Sockets : S10LD, S10LD-E, S10P, S10EP

### Approvals



# P10-T-A



**One Pole, Normally Open Twin Contact**

**6A 250V AC1 0.2A 220V DC1**  
**6A 30V DC1 0.5A 110V DC1**

## Pin Configuration

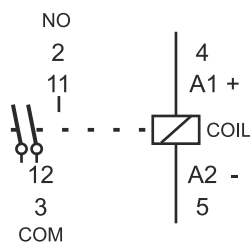

## Contacts

Materials : Standard	AgNi
Optional, code 1	AgNi + Au 0.2μ
Optional, code 2	AgNi + Au 5.0μ
Max. switching current	6 A
Max. Peak inrush current (20 ms.)	15 A
Max. Switching voltage	250 V
Max. AC load (Graph 1)	2.5 KVA
Max. DC load	See Graph 2*

## Graph 1 Electrical life, ops x 10<sup>6</sup>

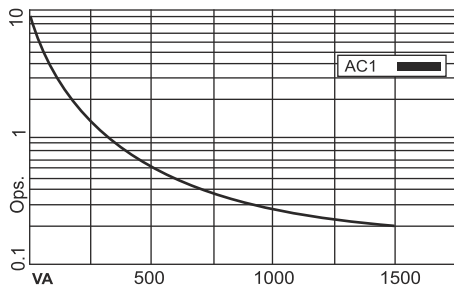

## Coils (Ohms ± 10% @ 20°C)

Pull-in voltage	≤ 0.8 x Un
Drop-out voltage	≥ 0.1 x Un
Nominal Coil Power	0.7 VA (AC) / 0.5 W (DC)

VAC	Ω	VDC	Ω
110	8,700	12	290
230	33,300	24	810
		60	5,000

## Graph 2 Max. DC load

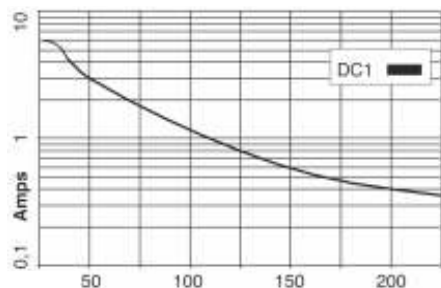

## Insulation

Dielectric strength (1 minute) :	
Open contacts	1 KV
Between Contacts & Coil	2 KV
Insulation resistance at 500VDC	100MΩ

## Specifications

Operate Time + Bounce Time	15ms max
Release Time + Bounce Time	15ms max
Ambient Temperature	-40°C (no ice)... +70°C
Mechanical life ops.	20 Million DC relays
Electrical life at nominal load	> 100,000 ops.
Operating frequency at nominal load	1,200 / hour
Protection (Graph 1)	IP40 / RT1
Weight Approx	18 gms.

## Dimensions in mm.

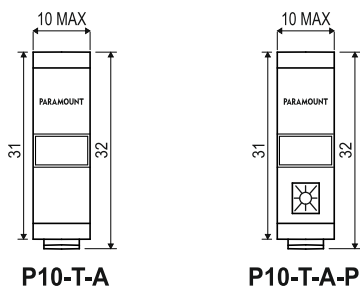
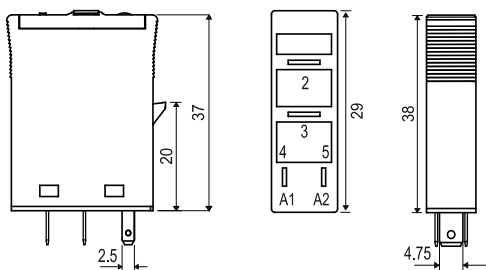

## Standard types

**AC 50 Hz : 110, 230**

**P** = LED  
**R** = R/C (110/230V) (Built in the Socket)  
**V** = Variastor (Built in the Socket)

**P10-T-A-P ...VAC**  
**P10-T-A-PR ...VAC**  
**P10-T-A-PV ...VAC**

**DC : 12, 24, 60**

**P** = LED  
**W** = Free-Wheeling Diodes  
**Z** = Polarity & Free-Wheeling Diodes  
**B** = AC/DC Bridge Rectifier (24/48V)  
(Built in the Socket)

**P10-T-A-P ...VDC**  
**P10-T-A-PW ...VDC**  
**P10-T-A-PZ ...VDC**  
**P10-T-A-PB ...VDC/AC**

**Suitable Sockets : S10LD-A, S10LD-A-E, S10P, S10EP**

## Approvals

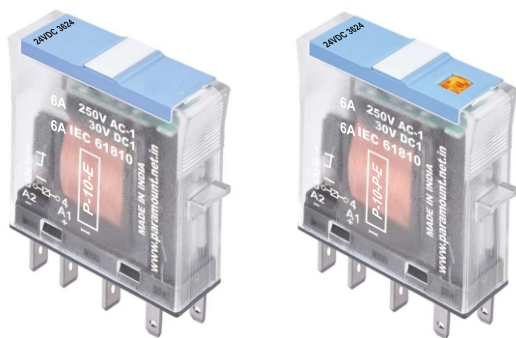

# P10-E



**One Pole, Change-Over Contact**  
**6A 250V AC1 0.2A 220V DC1**  
**6A 30V DC1 0.5A 110V DC1**

## Pin Configuration

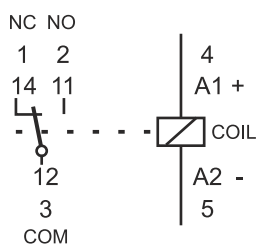

**Graph 1** Electrical life, ops x 10<sup>6</sup>

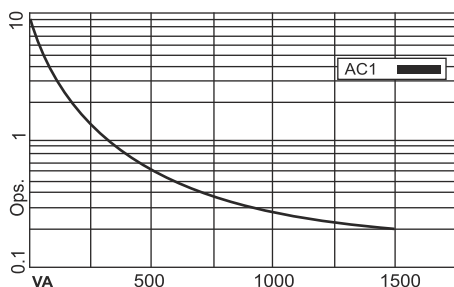

**Graph 2** Max. DC load

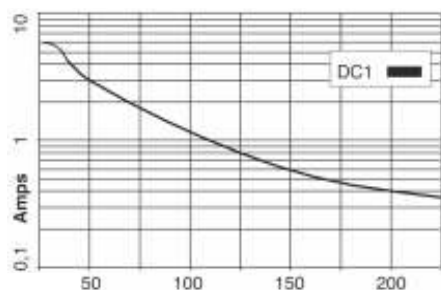

## Dimensions in mm.

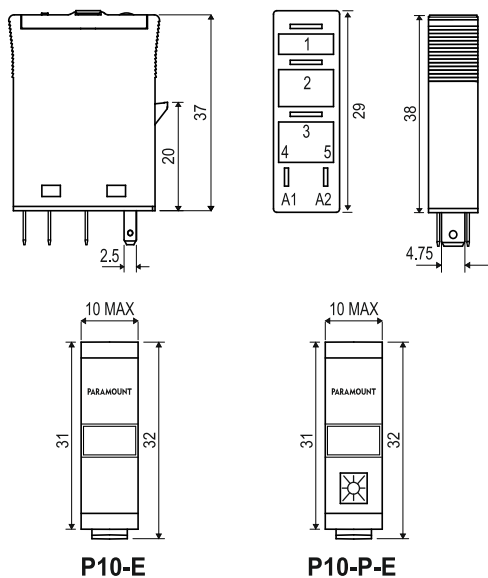

## Contacts

Materials : Standard	AgNi
Optional, code 1	AgNi + Au 0.2μ
Optional, code 2	AgNi + Au 5.0μ
Max. switching current	6 A
Max. Peak inrush current (20 ms.)	15 A
Max. Switching voltage	250 V
Max. AC load (Graph 1)	2.5 KVA
Max. DC load	See Graph 2*

## Coils (Ohms ± 10% @ 20°C)

Pull-in voltage	≤ 0.8 x Un
Drop-out voltage	≥ 0.1 x Un
Nominal Coil Power	0.7 VA (AC) / 0.5 W (DC)

VAC	Ω	VDC	Ω
110	8,700	12	290
230	33,300	24	810
		60	5,000

## Insulation

Dielectric strength (1 minute) :	
Open contacts	1 KV
Between Contacts & Coil	2 KV
Insulation resistance at 500VDC	100MΩ

## Specifications

Operate Time + Bounce Time	15ms max
Release Time + Bounce Time	15ms max
Ambient Temperature	-40°C (no ice)... +70°C
Mechanical life ops.	20 Million DC relays
Electrical life at nominal load	> 100,000 ops.
Operating frequency at nominal load	1,200 / hour
Protection (Graph 1)	IP40 / RT1
Weight Approx	18 gms.

## Standard types

<b>AC 50 Hz : 110, 230</b>	
P = LED	<b>P10-P-E ...VAC</b>
R = R/C (110/230V) (Built in the Socket)	<b>P10-PR-E ...VAC</b>
V = Variastor (Built in the Socket)	<b>P10-PV-E ...VAC</b>

<b>DC : 12, 24, 60</b>	
P = LED	<b>P10-P-E ...VDC</b>
W = Free-Wheeling Diodes	<b>P10-PW-E ...VDC</b>
Z = Polarity & Free-Wheeling Diodes	<b>P10-PZ-E ...VDC</b>
B = AC/DC Bridge Rectifier (24/48V) (Built in the Socket)	<b>P10-PB-E ...VDC/AC</b>

## Suitable Sockets : S10LD, S10LD-E, S10P, S10EP

## Approvals

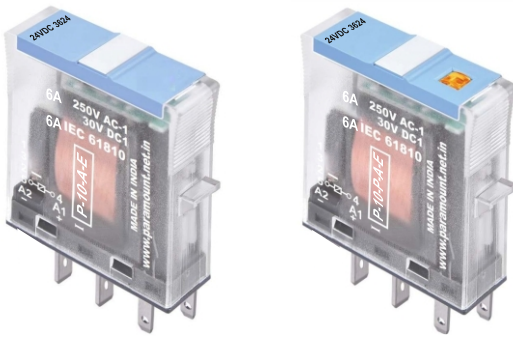

# P10-A...E

**One Pole, Normally Open Contact**

**6A 250V AC1 0.2A 220V DC1**  
**6A 30V DC1 0.5A 110V DC1**

## Pin Configuration

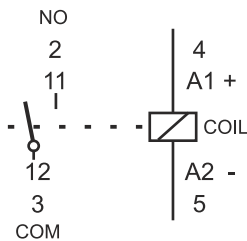

## Contacts

Materials : Standard	AgNi
Optional, code 1	AgNi + Au 0.2μ
Optional, code 2	AgNi + Au 5.0μ
Max. switching current	6 A
Max. Peak inrush current (20 ms.)	15 A
Max. Switching voltage	250 V
Max. AC load (Graph 1)	2.5 KVA
Max. DC load	See Graph 2*

## Graph 1 Electrical life, ops x 10<sup>6</sup>

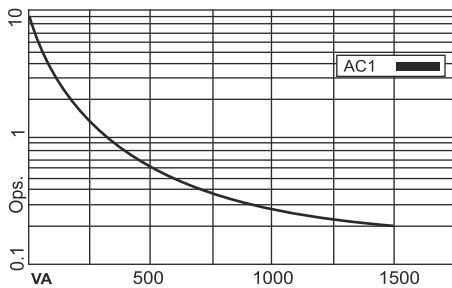

## Coils (Ohms ± 10% @ 20°C)

Pull-in voltage	≤ 0.8 x Un
Drop-out voltage	≥ 0.1 x Un
Nominal Coil Power	0.7 VA (AC) / 0.5 W (DC)

VAC	Ω	VDC	Ω
110	8,700	12	290
230	33,300	24	810
		60	5,000

## Graph 2 Max. DC load

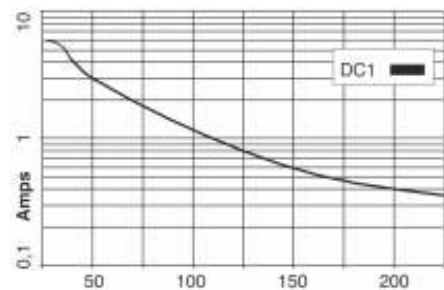

## Insulation

Dielectric strength (1 minute) :	
Open contacts	1 KV
Between Contacts & Coil	2 KV
Insulation resistance at 500VDC	100MΩ

## Dimensions in mm.

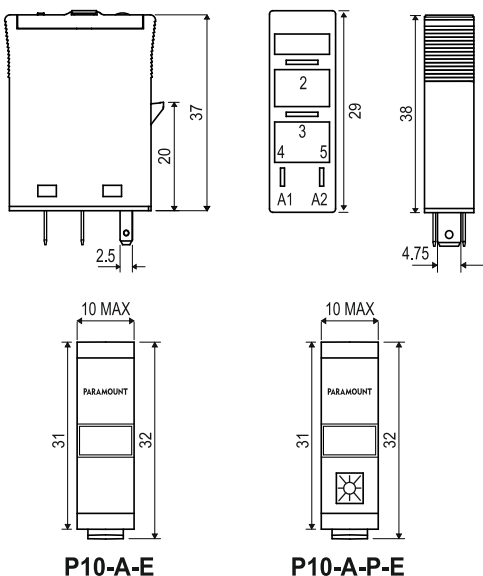

## Specifications

Operate Time + Bounce Time	15ms max
Release Time + Bounce Time	15ms max
Ambient Temperature	-40°C (no ice)... +70°C
Mechanical life ops.	20 Million DC relays
Electrical life at nominal load	> 100,000 ops.
Operating frequency at nominal load	1,200 / hour
Protection (Graph 1)	IP40 / RT1
Weight Approx	18 gms.

## Standard types

**AC 50 Hz : 110, 230**

**P** = LED  
**R** = R/C (110/230V) (Built in the Socket)  
**V** = Variastor (Built in the Socket)

**P10-A-P-E ...VAC**  
**P10-A-PR-E ...VAC**  
**P10-A-PV-E ...VAC**

**DC : 12, 24, 60**

**P** = LED  
**W** = Free-Wheeling Diodes  
**Z** = Polarity & Free-Wheeling Diodes  
**B** = AC/DC Bridge Rectifier (24/48V) (Built in the Socket)

**P10-A-P-E ...VDC**  
**P10-A-PW-E ...VDC**  
**P10-A-PZ-E ...VDC**  
**P10-A-PB-E ...VDC/AC**

**Suitable Sockets : S10LD-A, S10LD-A-E, S10P, S10EP**

## Approvals

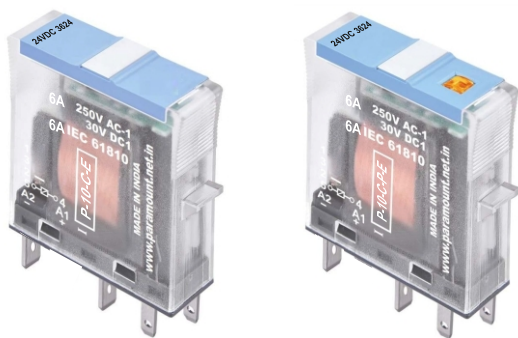

## P10-C-E



**One Pole, Normally Closed Contact**  
**6A 250V AC1 0.2A 220V DC1**  
**6A 30V DC1 0.5A 110V DC1**

### Pin Configuration

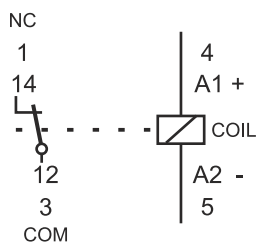

### Graph 1 Electrical life, ops x 10<sup>6</sup>

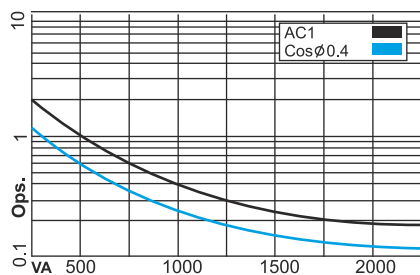

### Graph 2 Max. DC load

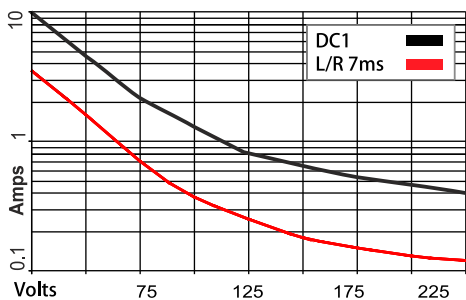

### Dimensions in mm.

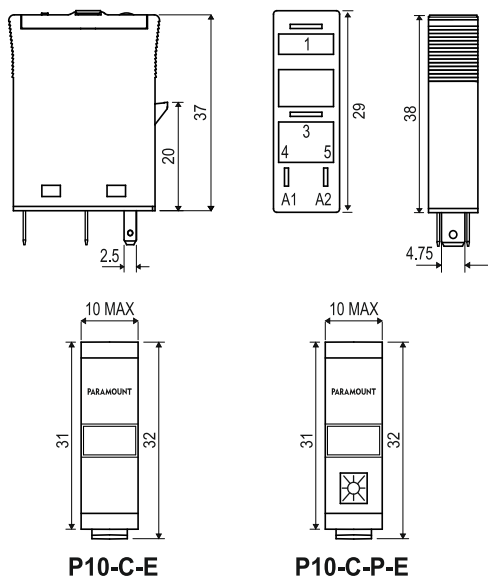

### Contacts

Materials : Standard AgNi  
 Optional, code 1 AgNi + Au 0.2μ  
 Optional, code 2 AgNi + Au 5.0μ  
 Max. switching current 6 A  
 Max. Peak inrush current (20 ms.) 15 A  
 Max. Switching voltage 250 V  
 Max. AC load (Graph 1) 2.5 KVA  
 Max. DC load See Graph 2\*

### Coils (Ohms ± 10% @ 20°C)

Pull-in voltage ≤ 0.8 x Un  
 Drop-out voltage ≥ 0.1 x Un  
 Nominal Coil Power 0.7 VA (AC) / 0.5 W (DC)

VAC	Ω	VDC	Ω
110	8,700	12	290
230	33,300	24	810
		60	5,000

### Insulation

Dielectric strength (1 minute) :  
 Open contacts 1 KV  
 Between Contacts & Coil 2 KV  
 Insulation resistance at 500VDC 100MΩ

### Specifications

Operate Time + Bounce Time 15ms max  
 Release Time + Bounce Time 15ms max  
 Ambient Temperature -40°C (no ice)... +70°C  
 Mechanical life ops. 20 Million DC relays  
 Electrical life at nominal load > 100,000 ops.  
 Operating frequency at nominal load 1,200 / hour  
 Protection (Graph 1) IP40 / RT1  
 Weight Approx 18 gms.

### Standard types

**AC 50 Hz : 110, 230**  
 P = LED  
 R = R/C (110/230V) (Built in the Socket)  
 V = Variastor (Built in the Socket)

**P10-C-P-E ...VAC**  
**P10-C-PR-E ...VAC**  
**P10-C-PV-E ...VAC**

**DC : 12, 24, 60**  
 P = LED  
 W = Free-Wheeling Diodes  
 Z = Polarity & Free-Wheeling Diodes  
 B = AC/DC Bridge Rectifier (24/48V) (Built in the Socket)

**P10-C-P-E ...VDC**  
**P10-C-PW-E ...VDC**  
**P10-C-PZ-E ...VDC**  
**P10-C-PB-E ...VDC/AC**

### Suitable Sockets : S10LD-C, S10LD-C-E, S10P, S10EP

### Approvals

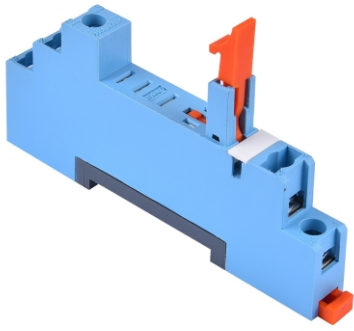

# S10LD

Only  
**11 mm**  
WIDE

**Input / Output Socket [10A] for  
P10 1C/O Relays DIN Rail or Panel Mountable**

## Wiring Diagram

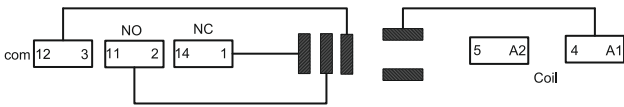

## Dimensions in mm.

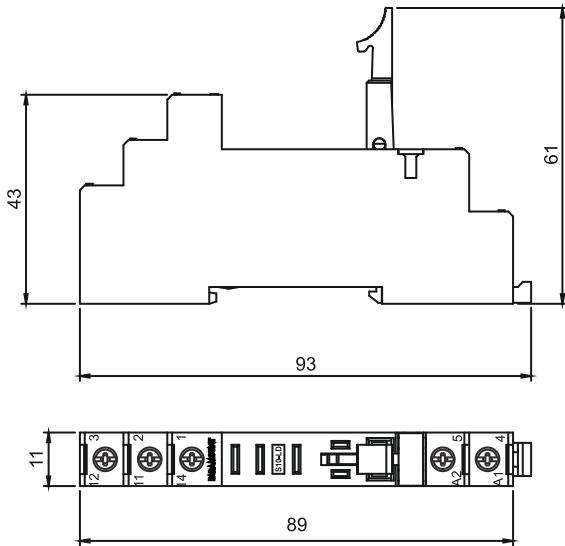

## Dimensions in mm.

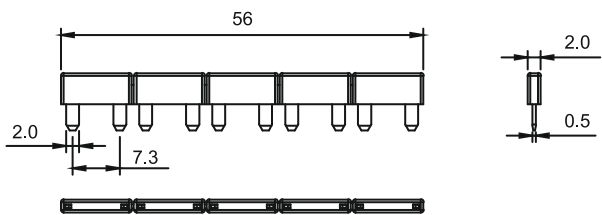

## Dimensions in mm.

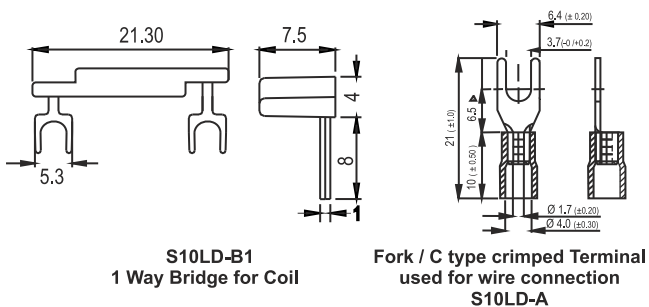

## Specifications

Poles	1 Change Over Contact
Nominal load :	10A / 250V
<b>Insulation</b> : Di-electric strength, 1 minute	
Between contact and coil	5 KV
Between all terminals and DIN Rail	5 KV
Between adjacent terminals	3 KV
Brass Tin Plated Screw	
Max. screw torque	0.6 Nm
Screw dimensions	M3, Pozi
<b>Wire in-lets capacity :</b>	
Solid Wire	4 mm <sup>2</sup> or 2 x 2.25 mm <sup>2</sup>
Multi core	22 14 AWG
Ferrule tip terminals	4 mm <sup>2</sup>

## Other Aspects

Weight Approx	26 gms
DIN Rail / Panel Mountable	
Integrated Relay Hold Down Clip	
Removable White Marking Label	
EN / DIN Sequential Numbering according to EN 60947 & IEC 61810	

## Accessories 1 (Internal Bridges)



Looping Bridge Bar (A2-ve), 5 way  
**S10LD-B5**

## Accessories 2 (External Bridges)



**S10LD-B1**



**C Terminal**

## Suitable Relays : P10, P10-E

## Approvals

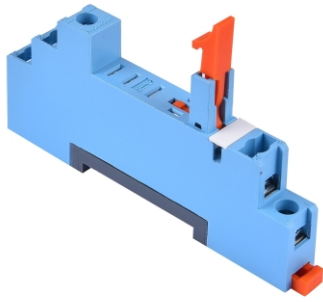

# S10LD-A

Only  
**11 mm**  
WIDE

**Input / Output Socket [10A] for  
P10 1NO Relays DIN Rail or Panel Mountable**

## Wiring Diagram

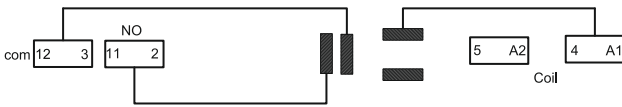

## Dimensions in mm.

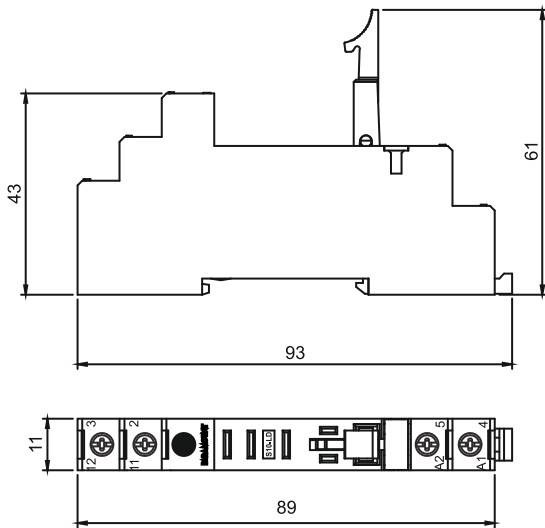

## Dimensions in mm.

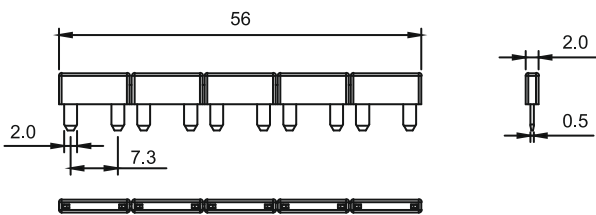

## Dimensions in mm.

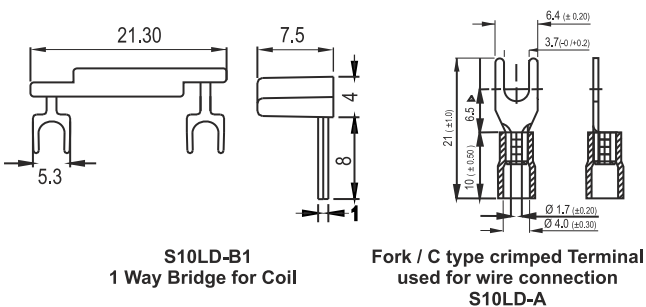

## Specifications

Poles	1 Normally Open Contact
Nominal load :	10A / 250V
<b>Insulation</b> : Di-electric strength, 1 minute	
Between contact and coil	5 KV
Between all terminals and DIN Rail	5 KV
Between adjacent terminals	3 KV
Brass Tin Plated Screw	
Max. screw torque	0.6 Nm
Screw dimensions	M3, Pozi
<b>Wire in-lets capacity :</b>	
Solid Wire	4 mm <sup>2</sup> or 2 x 2.25 mm <sup>2</sup>
Multi core	22 14 AWG
Ferrule tip terminals	4 mm <sup>2</sup>

## Other Aspects

Weight Approx	26 gms
DIN Rail / Panel Mountable	
Integrated Relay Hold Down Clip	
Removable White Marking Label	
EN / DIN Sequential Numbering according to EN 60947 & IEC 61810	

## Accessories 1 (Internal Bridges)



Looping Bridge Bar (A2-ve), 5 way  
**S10LD-B5**

## Accessories 2 (External Bridges)



**S10LD-B1**



**C Terminal**

## Suitable Relays : P10-A, P10-A-E

## Approvals

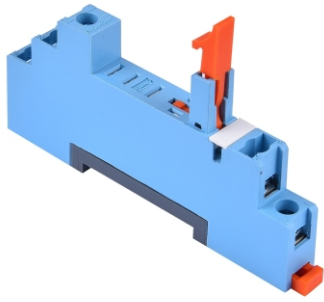

# S10LD-C

Only  
**11 mm**  
WIDE

**Input / Output Socket [10A] for  
P10 1NC Relays DIN Rail or Panel Mountable**

## Wiring Diagram



## Dimensions in mm.

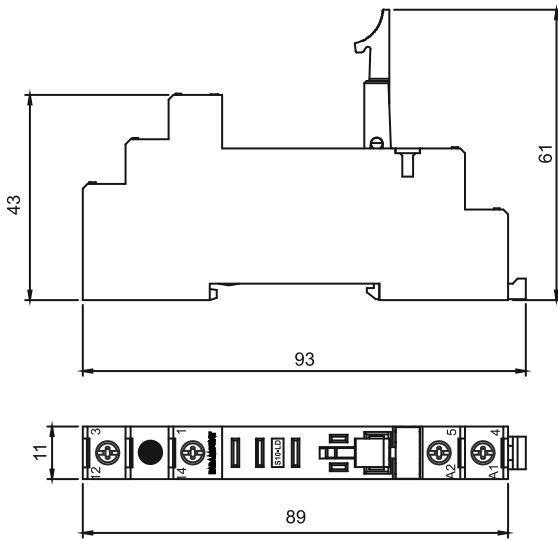

## Dimensions in mm.

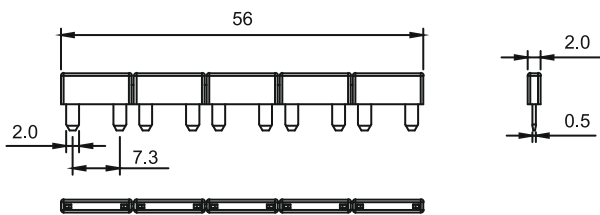

## Dimensions in mm.

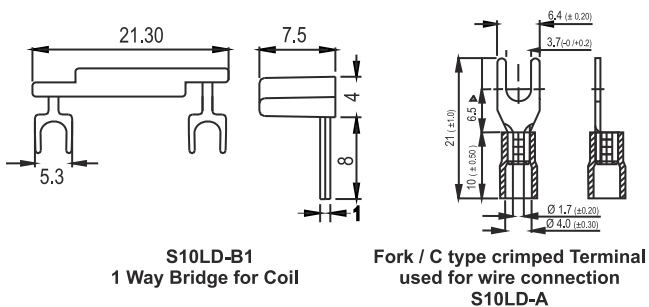

S10LD-B1  
1 Way Bridge for Coil

Fork / C type crimped Terminal  
used for wire connection  
S10LD-A

## Specifications

Poles	1 Normally Closed Contact
Nominal load :	10A / 250V
<b>Insulation</b> : Di-electric strength, 1 minute	
Between contact and coil	5 KV
Between terminals and DIN Rail	5 KV
Between adjacent terminals	3 KV
Brass Tin Plated Screw	
Max. screw torque	0.6 Nm
Screw dimensions	M3, Pozi
<b>Wire in-lets capacity :</b>	
Solid Wire	4 mm <sup>2</sup> or 2 x 2.25 mm <sup>2</sup>
Multi core	22 14 AWG
Ferrule tip terminals	4 mm <sup>2</sup>

## Other Aspects

Weight Approx	26 gms
DIN Rail / Panel Mountable	
Integrated Relay Hold Down Clip	
Removable White Marking Label	
EN / DIN Sequential Numbering according to EN 60947 & IEC 61810	

## Accessories 1 (Internal Bridges)



Looping Bridge Bar (A2-ve), 5 way  
**S10LD-B5**

## Accessories 2 (External Bridges)



**S10LD-B1**



**C Terminal**

## Suitable Relays : P10-C, P10-C-E

## Approvals



# S10P

Only **11 mm** WIDE

**Printed Circuit Board  
Socket for P10 Relays**

## Dimensions in mm.

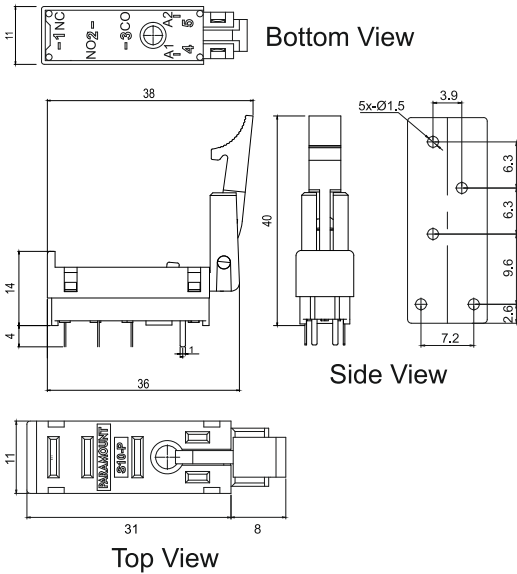

## Specifications

Nominal load	10A / 250 V
Dielectric strength 1 min.	
Coil terminals to contacts	5 KV
Hard brass tin-plated terminals	0.3 x 1mm
Integrated Relay Hold Down Clip	
Weight Approx.	5 gms.

**Suitable Relays : All types of P10**

**Approvals**



# S10EP

Only **11 mm** WIDE

**Printed Circuit Board  
Socket for P10 Relays**

## Dimensions in mm.

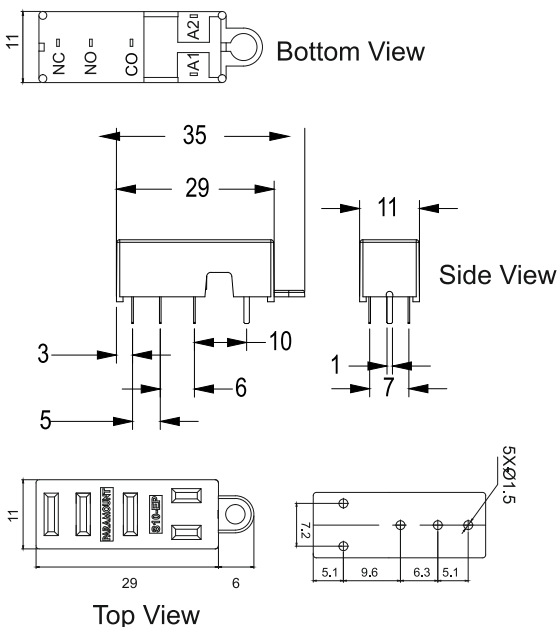

## Specifications

Nominal load	10A / 250 V
Dielectric strength 1 min.	
Coil terminals to contacts	5 KV
Hard brass tin-plated terminals	0.3 x 1mm
Integrated Relay Hold Down Clip	
Weight Approx.	2.5 gms.

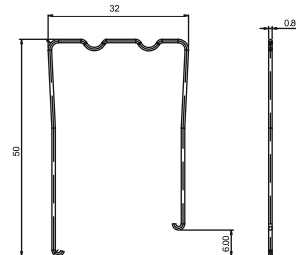

**Suitable Relays : All types of P10**

**Approvals**

### Ordering Information for Relays

P10 -  -  -  -  -  -  -   
           1      2      3      4      5      6      7

#### 1. Relay Type

Blank : Genera Purpose / Standard

T : Twin Contact / Bifurcated Relay

#### 2. Contact Form

Blank : SPDT (1C/O)

A : SPST - NO (1N/O)

C : SPCT - NC (1N/C)

#### 3. Features

P : LED Indicator across the coil

W : Free Wheeling Diode

Z : Free Wheeling + Polarity Diode

R : R/C (110/230V) (Built in the Socket)

V : Variastor (Built in the Socket)

B : AC/DC Bridge Rectifier (24/48V) (Built in the Socket)

#### 4. Special Type

Blank : No Features / Standard

#### 5. Contact Material

Blank : AgCuNi

1 : AgNi + Au 0.2μ

2 : AgNi + Au 5.0μ

#### 6. Approval

Blank : UL Approved (10 Amps)

E : UL Approved (6 Amps)

E1 : NON UL Approved (10 Amps)

E2 : NON UL Approved (6 Amps)

#### 7. Rated coil Voltage

VDC : 12, 24, 60

VAC : 110, 230

### Ordering Information for Sockets for P10 Relays

S10LD	Din Rail Mountable Socket	(UL Approved)	For General purpose 1 CO Pole Relays
S10LD-A	Din Rail Mountable Socket	(UL Approved)	For General purpose 1 NO Relays
S10LD-C	Din Rail Mountable Socket	(UL Approved)	For General purpose 1 NC Relays
S10LD-E	Din Rail Mountable Socket	(NON UL)	For General purpose 1 CO Pole Relays
S10LD-A-E	Din Rail Mountable Socket	(NON UL)	For General purpose 1 NO Relays
S10LD-C-E	Din Rail Mountable Socket	(NON UL)	For General purpose 1 NC Relays

**Paramount Industries**

# 70, 5th Cross, SSI Area, Rajajinagar,  
Bangalore - 560 010, India.

**Email** : [info@paramount.net.in](mailto:info@paramount.net.in)

**Website** : [www.paramount.net.in](http://www.paramount.net.in)

Specification may change in the view of product improvement without prior intimation.